



**Winbond W55Fxxx**

**Serial Flash Memory**

**Data Sheet**

# W55FXX DATA SHEET



## 1. GENERAL DESCRIPTION

The W55Fxx is a serial flash memory series that is typically used as the contents upgradeable memory device of Internet toy applications, or applications with W51300 (*VoiceRecorder™* controller) for voice message storage device. Besides that, W55Fxx can still be the W551Cxxx (Serial Voice Memory) program or data emulator. The single voltage supply eliminates the need for an extra pump circuit during flash memory cells programming and erasing.

### 1.1 W55Fxx Product Selection Guide

W55Fxx Serial Flash Memory is used to store pre-determined data or contents need to be upgradeable applications. To communicate with W55Fxx in serial data mode, the connection interface total pin counts can be reduced to five pins only. The following table is shown the product selection guide of part number vs. memory density.

PART #	W55F01*	W55F01B*	W55F05B*	W55F10A	W55F10B*	W55F10BG	W55F20
Density	128K bits	128K bits	512K bits	1M bits	1M bits	1M bits	2M bits

#### Notice:

1. \* indicated prohibits cascade application just for single chip application only.
2. W55F10BG is lead free package version.
3. Programming voltage: W55Fxxx for high voltage (5Vmin.).

# W55FXXX DATA SHEET



## 2. FEATURES

### 2.1 W55Fxx Features Description

- ❑ Provides CLK, ADDR, and DATA connection interface pins to communicate with other controllers such as Winbond *PowerSpeech™*, *BandDirector™*, *ViewTalk™*, ..... Series.
- ❑ 128K/512K/1M/2M bits memory density available.
- ❑ Directly cascadable for longer duration applications ( except for W55F01 and W55F05B).
- ❑ Fast frame-write operation
  - Frame (32 bits) program cycle time: **400 μS (typ.)**
- ❑ Fast whole-chip-erase duration: **50 mS (max.)**
- ❑ Read data access time: **500 nS (max.)**
- ❑ Program/erase cycles: **100,000 (typ.)**
- ❑ **Programming voltage: 5V min.**
- ❑ Data retention: **10 years (typ.)**
- ❑ Low power consumption:
  - Operating: **5 mA (typ.)**
  - Standby: **2 μA (typ.)**
- ❑ 8L PDIP Lead free package for W55F10A and W55F10B only.

### 2.2 W55Fxx Pin Configuration & Description

#### Pin Configuration

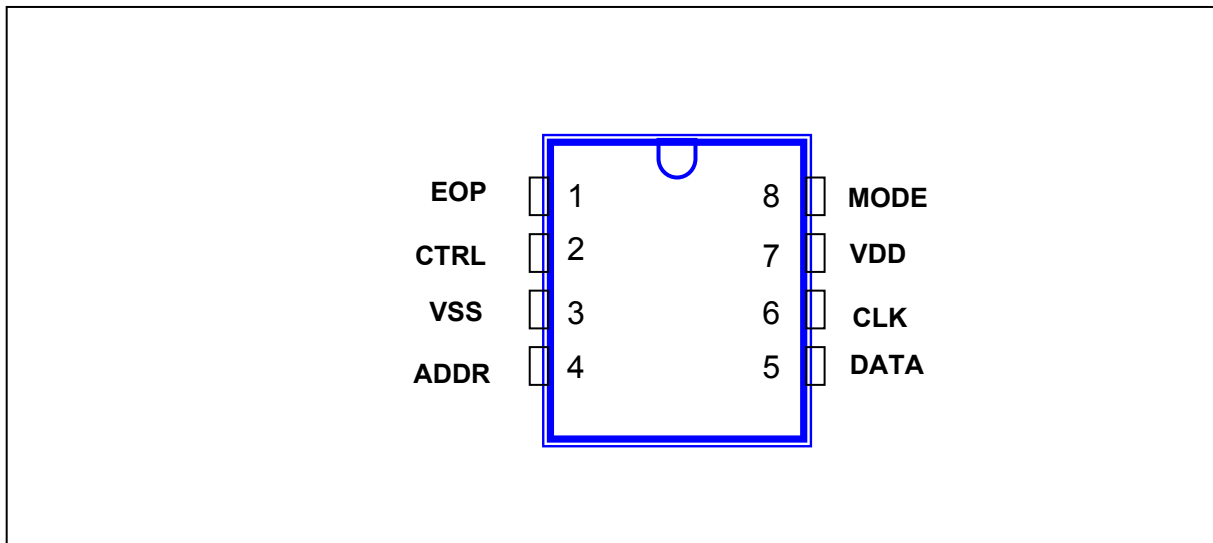

# W55FXX DATA SHEET



### Pin Description

NO.	PIN NAME	I/O	DESCRIPTION
1	EOP	O	End of process signal output.
2	CTRL	I	Enable signal for program and erase operations when MODE = 0, Input clock for mode counter when MODE = 1.
3	VSS	I	Ground
4	ADDR	I	Input clock for start adress shift-in.
5	DATA	I/O	Bi-directional data line.
6	CLK	I	Input clock for data write-in and read-out.
7	VDD	I	Positive voltage supply.
8	MODE	I	Mode select control pin.

### 2.3 W55Fxx System Block Diagram

W55Fxx Block Diagram

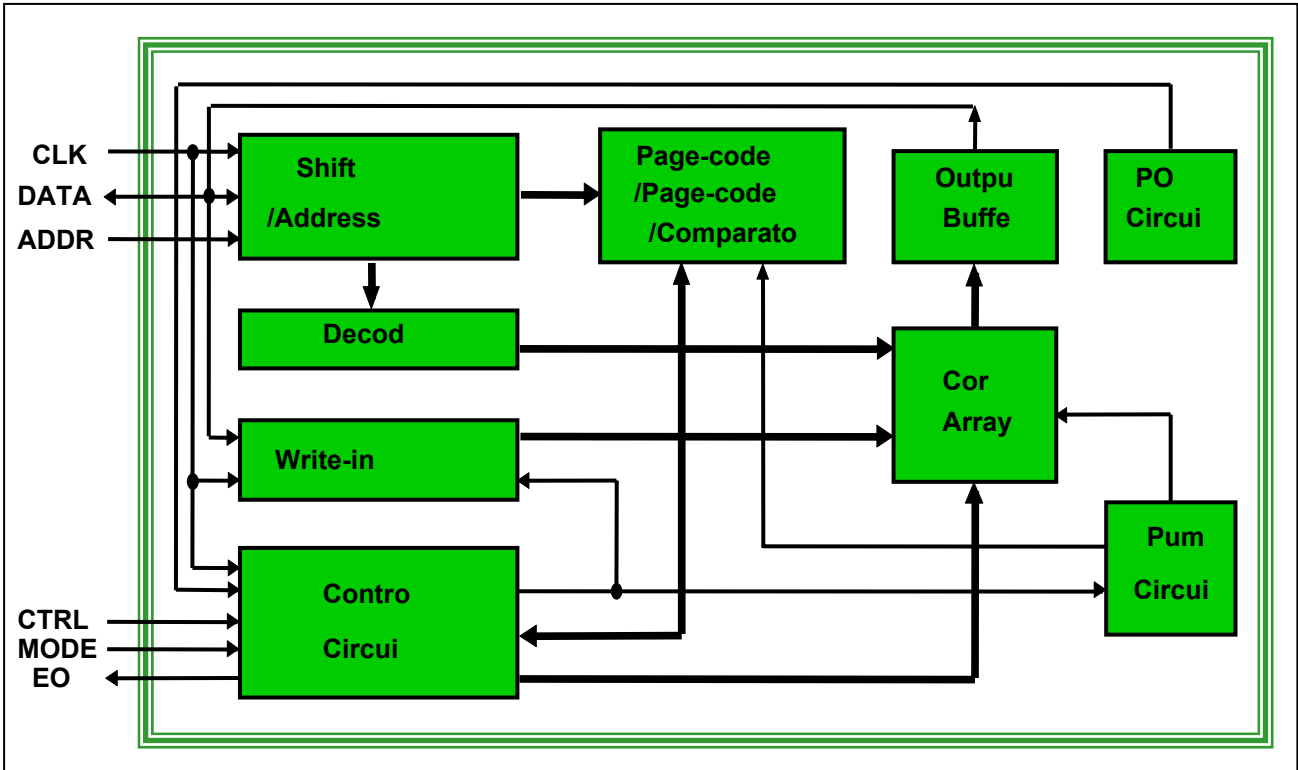

# W55FXXX DATA SHEET



## 3. ELECTRICAL CHARACTERISTICS

### 3.1 W55Fxx Absolute Maximum Ratings

PARAMETER	SYMBOL	CONDITION	RATED VALUE	UNIT
Operating Temp.	TOPR	-	0 to +70	°C
Storage Temp.	TSTG	-	-65 to +150	°C
Power Supply	VDD-VSS	-	-0.3 to +7.0	V
Input DC Voltage	VDC	All pins	-0.5 to VDD +1.0	V
Transient Voltage (< 20 nS)	VTRAN	All pins	-1.0 to VDD +1.0	V

**Note:** Exposure to conditions beyond those listed under Absolute Maximum Ratings may adversely affect the life and reliability of the device.

### 3.2 W55Fxx DC Characteristics

(VDD = 5V, VSS = 0V, TA = 25° C)

PARAMETER	SYMBOL	CONDITION	LIMITS			UNIT	
			MIN.	TYP.	MAX.		
Operating voltage	VDD	Read mode	2.4	4.5	5.5	V	
Programming voltage	VDD	Erase & Write Mode	5	-	5.5	V	
Standby current	ISB	All inputs = GND DATA & EOP open	-	2	4	μA	
Operating current	IOP	In read mode DATA & EOP open FOOSC = 1 MHz	-	5	10	mA	
Input voltage	High	All input pins	2.0		VDD	V	
	Low		VIL	-0.3	-	0.8	V
Output current	Sink	IOL	VOL = 0.5V	2.5	5	-	mA
	Drive	IOH	VOH = 4.0V	-2.5	-5	-	mA
Input leakage current of CTRL, MODE	ILI1	VIN = 4.5V	-	-	4.5	μA	
Input leakage current of DATA	ILI2	VIN = 0V	-	-	-4.5	μA	

# W55FXX DATA SHEET



## 3.3 W55Fxx AC Characteristics

(VDD = 5V, VSS = 0V, TA = 25° C)

PARAMETER	SYMBOL	CONDITIONS	MIN.	TYP.	MAX.	UNIT
MODE pulse width	TMP	-	1	-	-	μS
CTRL pulse width	TWP	Page coding mode	400	-	2000	μS
Clock frequency of ADDR	FADDR	-	-	-	1	MHz
Clock frequency of CLK	FCLK	-	-	-	1	MHz
Clock frequency of CTRL	FCTRL	-	-	-	1	MHz
Interval between ADDR end & CLK begin	TI	Read/Write mode	1	-	-	μS
Interval between CLK & CTRL	TGCC	Write mode	1	-	-	μS
Interval between ADDR & CTRL	TGCA	Page coding mode	1	-	-	μS
Interval between addressing end & block-erase begin	TAE	Block erase mode	1	-	-	μS
Interval between MODE rising edge & CTRL clock begin	TMB	Mode selection	500	-	-	nS
Interval between CTRL clock end & MODE falling edge	TME	Mode selection	500	-	-	nS
Interval between MODE falling edge & another pin active	TGM	-	1	-	-	μS
Data access time	TRA	Read mode	-	-	500	nS
Data set up time	TWS	Write mode	250	-	-	nS
	TAS	-	250	-	-	nS
Data hold time	TRH	Read mode	0	-	-	nS
	TWH	Write mode	10	-	-	nS
	TAH	-	10	-	-	nS
Programming duration	TPR	Write mode	400	-	2000	μS
Whole-chip-erase time	TWE	Whole-chip-erase mode	45	-	50	mS
Block-erase time	TBE	Block-erase mode	40	-	45	mS

# W55FXXX DATA SHEET



## 4. TIMING WAVEFORM

### 4.1 W55Fxx Timing Waveform

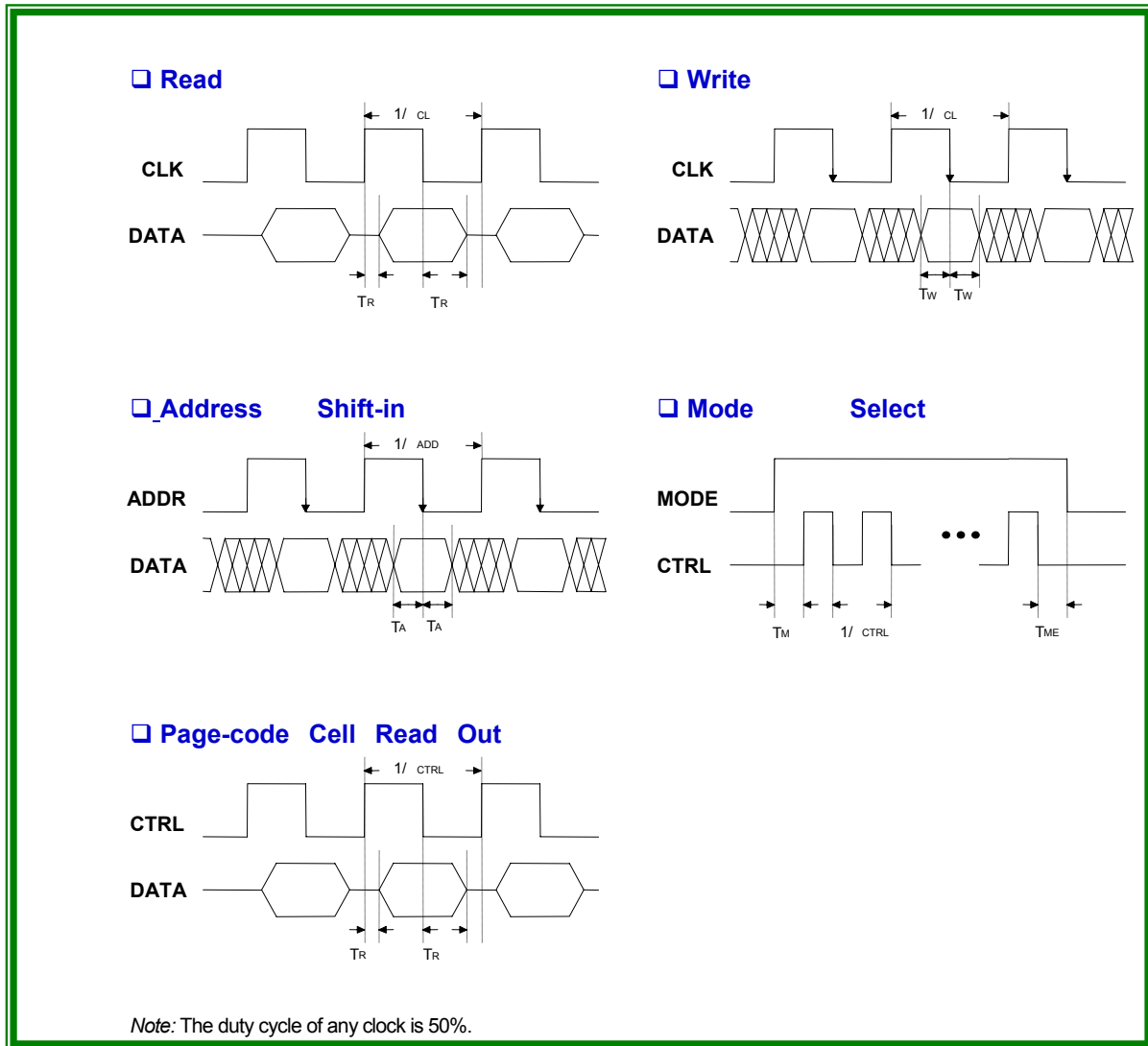



## 5. APPLICATIONS

### 5.1 W55Fxx Applications

#### □ Winbond e-mail Reminder & Downloader application:

##### System Solution W55FC200+W55Fxx+W58300

##### ➤ e-mail Reminder:

In-coming e-mail Indication & Reminder (W55FC200).  
Upgradeable "Greeting words" or "Music" from web site.

##### ➤ Contents Downloader:

Web site contents "Plug-&-Download" to Flash memory Card (W55Fxx).  
Flash memory contents "Plug-&-Play" by *PowerSpeech* (W58300), *ViewTalk* (W536xxxx)

#### □ Winbond Voice Mail Loader:

##### System Solution W55FC200+W55F20+W51300

##### ➤ Voice Mail Uploader:

Message recording by "VoiceRecorder (W51300)", upload to PC & save as an e-mail file by "Uploader (W55FC200)".  
Voice message sending by e-mail.

##### ➤ Voice Mail Downloader:

Message download from PC by "Downloader (W55FC200)", message play back by "VoicePlayer (W51300)".  
LED flashing indication for voice playing

# W55FXXX DATA SHEET



## 5.2 W55Fxx Application Circuits

### W55Fxx Application Circuits (for reference only)

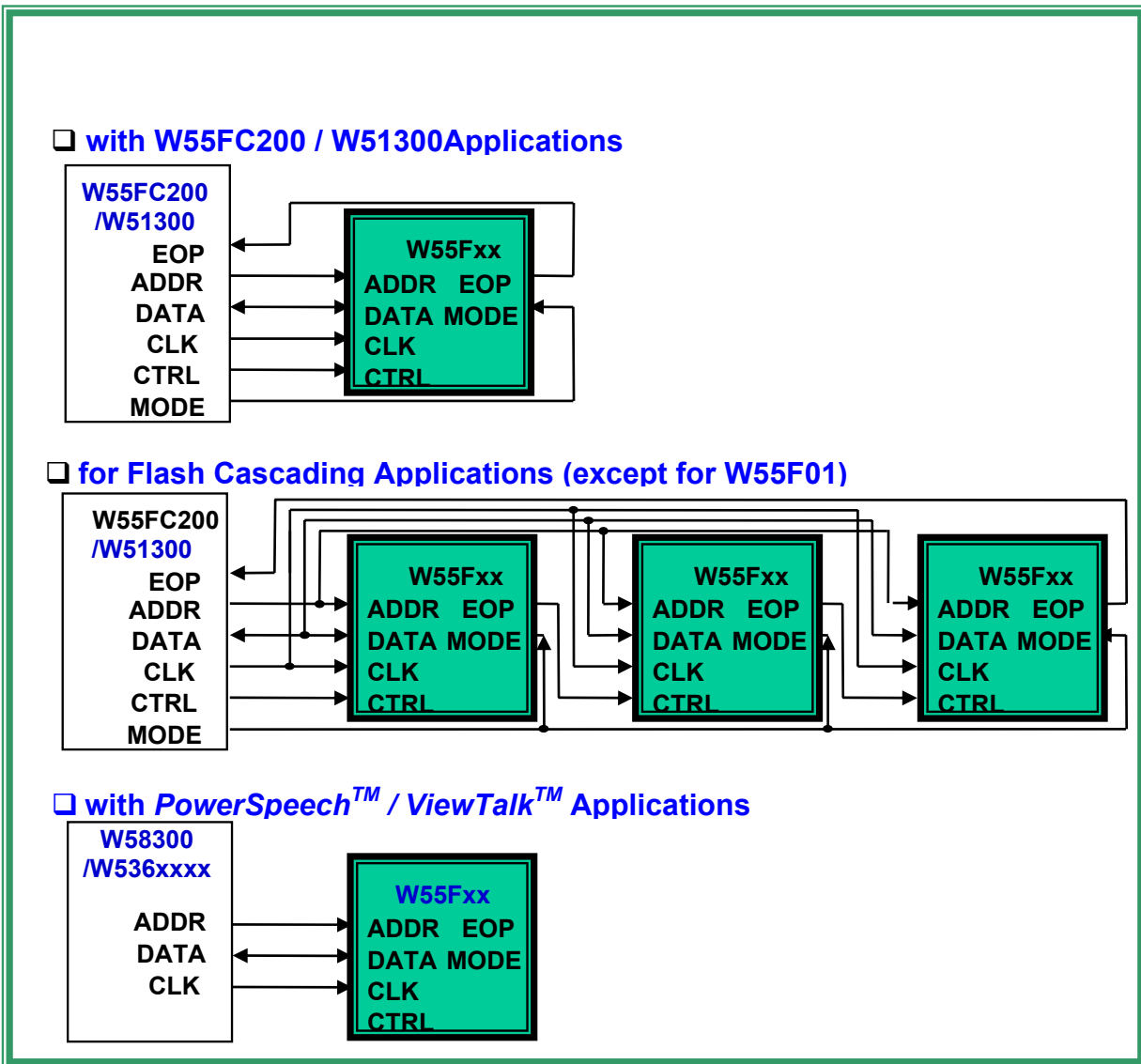

# W55FXX DATA SHEET



## W55Fxx Programming Power Supply With DC/DC Application Circuit, (for reference only)

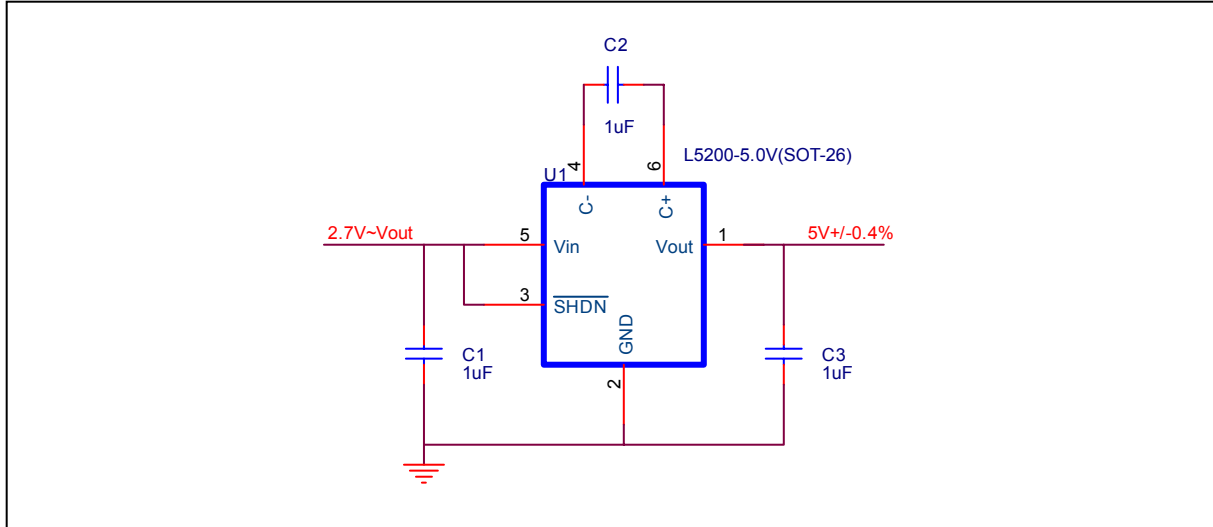

## W55Fxx Data Sheet Version Change List

	DATE	VERSION	REMARK
1	05/17/2002	A	New creation
2	03/12/2004	B	Add new part number W55F10B
3	01/21/2005	C	Add lead-free package version
4	03/29/2005	D	Add new part number W55F01B.
5	07/04/2005	E	Change programming time period (TWP).
6	08/09/2005	F	1. Add W55FxxxL series for low voltage programming application. 2. Add programming voltage DC parameters definition. 3. Change programming time period (TPR).
7	08/24/2005	A1.6	Change revision number.
8	12/05/2005	A1.7	1. Modify programming operation voltage to 5.0 Voltage. 2. Add DC/DC circuit for programming supply power.
9	05/02/2006	A1.8	1. Modify programming operation voltage to 5.0 Voltage. 2. Add DC/DC circuit for programming supply power. 3. Add W55F10BG for lead free package.

# W55FXXX DATA SHEET



## Important Notice

Winbond products are not designed, intended, authorized or warranted for use as components in systems or equipment intended for surgical implantation, atomic energy control instruments, airplane or spaceship instruments, transportation instruments, traffic signal instruments, combustion control instruments, or for other applications intended to support or sustain life. Further more, Winbond products are not intended for applications wherein failure of Winbond products could result or lead to a situation wherein personal injury, death or severe property or environmental damage could occur.

Winbond customers using or selling these products for use in such applications do so at their own risk and agree to fully indemnify Winbond for any damages resulting from such improper use or sales.



### Headquarters

No. 4, Creation Rd. III,  
Science-Based Industrial Park,  
Hsinchu, Taiwan  
TEL: 886-3-5770066  
FAX: 886-3-5665577  
<http://www.winbond.com.tw/>

### Taipei Office

9F, No.480, Rueiguang Rd.,  
Neihu District, Taipei, 114,  
Taiwan, R.O.C.  
TEL: 886-2-8177-7168  
FAX: 886-2-8751-3579

### Winbond Electronics Corporation America

2727 North First Street, San Jose,  
CA 95134, U.S.A.  
TEL: 1-408-9436666  
FAX: 1-408-5441798

### Winbond Electronics Corporation Japan

7F Daini-ueno BLDG, 3-7-18  
Shinyokohama Kohoku-ku,  
Yokohama, 222-0033  
TEL: 81-45-4781881  
FAX: 81-45-4781800

### Winbond Electronics (Shanghai) Ltd.

27F, 2299 Yan An W. Rd. Shanghai,  
200336 China  
TEL: 86-21-62365999  
FAX: 86-21-62365998

### Winbond Electronics (H.K.) Ltd.

Unit 9-15, 22F, Millennium City,  
No. 378 Kwun Tong Rd.,  
Kowloon, Hong Kong  
TEL: 852-27513100  
FAX: 852-27552064

*Please note that all data and specifications are subject to change without notice.  
All the trademarks of products and companies mentioned in this datasheet belong to their respective owners.*