



Product Specification

AU OPTRONICS CORPORATION

(V) Preliminary Specifications

() Final Specifications

Module	11.6”(11.57”) HD 16:9 Color TFT-LCD with LED Backlight design
Model Name	B116XW03 V1 (H/W:0A)
Note ()	<i>LED Backlight with driving circuit design</i>

Customer	Date
Checked & Approved by	Date
Note: This Specification is subject to change without notice.	

Approved by	Date
<u>CH Lin</u>	<u>12/09/2009</u>
Prepared by	Date
<u>Jeff Hou</u>	<u>12/09/2009</u>
NBBU Marketing Division AU Optronics corporation	



2. General Description

B116XW03 V1 is a Color Active Matrix Liquid Crystal Display composed of a TFT LCD panel, a driver circuit, and LED backlight system. The screen format is intended to support the 16:9 HD, 1366(H) x768(V) screen and 262k colors (RGB 6-bits data driver) with LED backlight driving circuit. All input signals are LVDS interface compatible.

B116XW03 V1 is designed for a display unit of notebook style personal computer and industrial machine.

2.1 General Specification

The following items are characteristics summary on the table at 25 °C condition:

Items	Unit	Specifications			
Screen Diagonal	[mm]	293.8			
Active Area	[mm]	256.125 X 144.0			
Pixels H x V		1366x3(RGB) x 768			
Pixel Pitch	[mm]	0.1875 x 0.1875			
Pixel Format		R.G.B. Vertical Stripe			
Display Mode		Normally White			
White Luminance (ILED=20mA) (Note: ILED is LED current)	[cd/m ²]	200 typ. (5 points average) 180 min. (5 points average)			
Luminance Uniformity		1.25 max. (5 points)			
Contrast Ratio		500 typ			
Response Time	[ms]	8 typ / 16 Max			
Nominal Input Voltage VDD	[Volt]	+3.3 typ.			
Power Consumption	[Watt]	2.9 max. (Include Logic and BLU power)			
Weight	[Grams]	235 max.			
Physical Size Include bracket	[mm]		Min.	Typ.	Max.
		Length	277.5	278.0	278.5
		Width	167.5	168.0	168.5
		Thickness	-	-	3.6
Electrical Interface		1 channel LVDS			
Glass Thickness	[mm]	0.5			
Surface Treatment		Anti-Glare,			
Support Color		262K colors (RGB 6-bit)			



Product Specification

AU OPTRONICS CORPORATION

Temperature Range Operating	[°C]	0 to +50
Storage (Non-Operating)	[°C]	-20 to +60
RoHS Compliance		RoHS Compliance

2.2 Optical Characteristics

The optical characteristics are measured under stable conditions at 25°C (Room Temperature) :

Item	Symbol	Conditions	Min.	Typ.	Max.	Unit	Note
White Luminance $I_{LED=20mA}$		5 points average	180	200	-	cd/m ²	1, 4, 5.
Viewing Angle	θ_R	Horizontal (Right) CR = 10 (Left)	40	45	-	degree	4, 9
	θ_L		40	45	-		
	ϕ_H	Vertical (Upper) CR = 10 (Lower)	10	15	-		
	ϕ_L		30	35	-		
Luminance Uniformity	δ_{5P}	5 Points	-	-	1.25		1, 3, 4
Luminance Uniformity	δ_{13P}	13 Points	-	-	1.50		2, 3, 4
Contrast Ratio	CR		400	500	-		4, 6
Cross talk	%				4		4, 7
Response Time	T_r	Rising	-	3	-	msec	4, 8
	T_f	Falling	-	5	-		
	T_{RT}	Rising + Falling	-	8	16		
Color / Chromaticity Coordinates	Red	Rx	CIE 1931	0.554	0.584	0.614	4
		Ry		0.303	0.333	0.363	
	Green	Gx		0.308	0.338	0.368	
		Gy		0.541	0.571	0.601	
	Blue	Bx		0.128	0.158	0.188	
		By		0.103	0.133	0.163	
	White	Wx		0.283	0.313	0.343	
		Wy		0.299	0.329	0.359	
	NTSC	%			-	45	

Note 1: 5 points position (Ref: Active area)

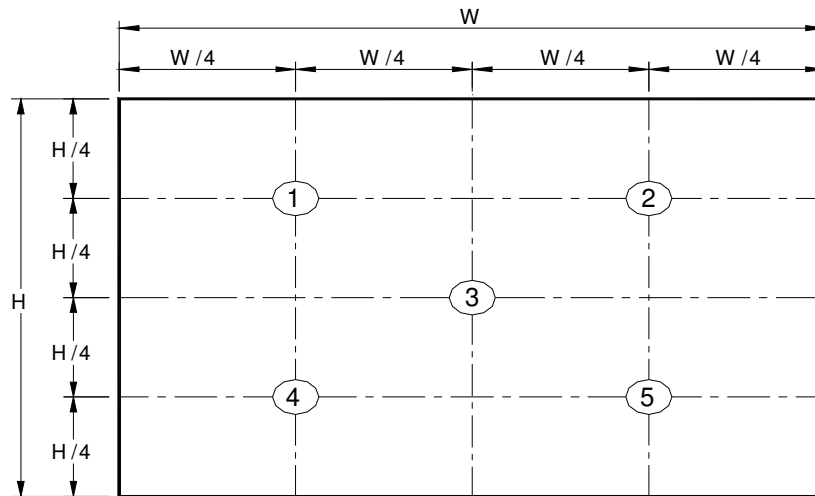

Note 2: 13 points position (Ref: Active area)

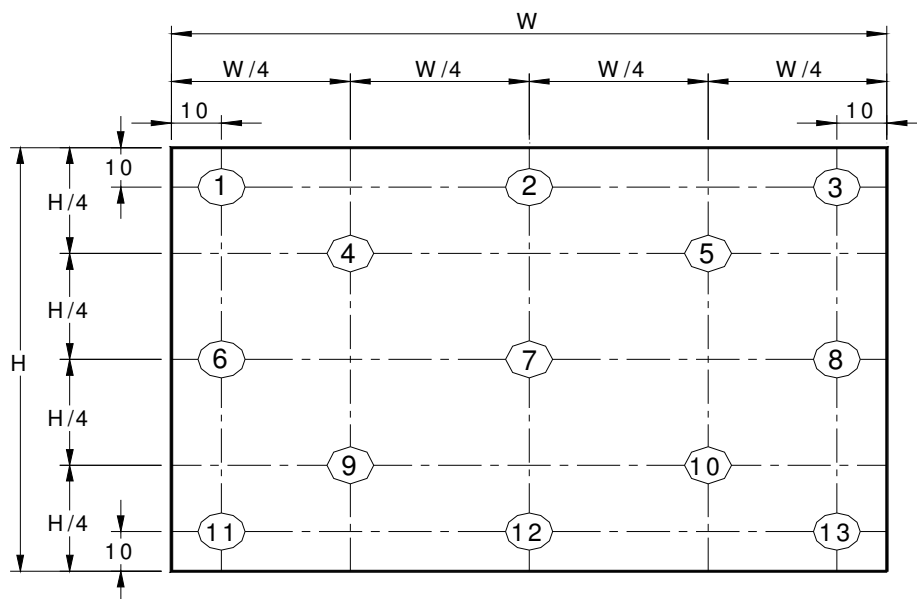

Note 3: The luminance uniformity of 5 or 13 points is defined by dividing the maximum luminance values by the minimum test point luminance

$$\delta_{w5} = \frac{\text{Maximum Brightness of five points}}{\text{Minimum Brightness of five points}}$$

$$\delta_{w13} = \frac{\text{Maximum Brightness of thirteen points}}{\text{Minimum Brightness of thirteen points}}$$

Note 4: Measurement method

The LCD module should be stabilized at given temperature for 30 minutes to avoid abrupt temperature change during measuring. In order to stabilize the luminance, the measurement should be executed after lighting

Backlight for 30 minutes in a stable, windless and dark room, and it should be measured in the center of screen.

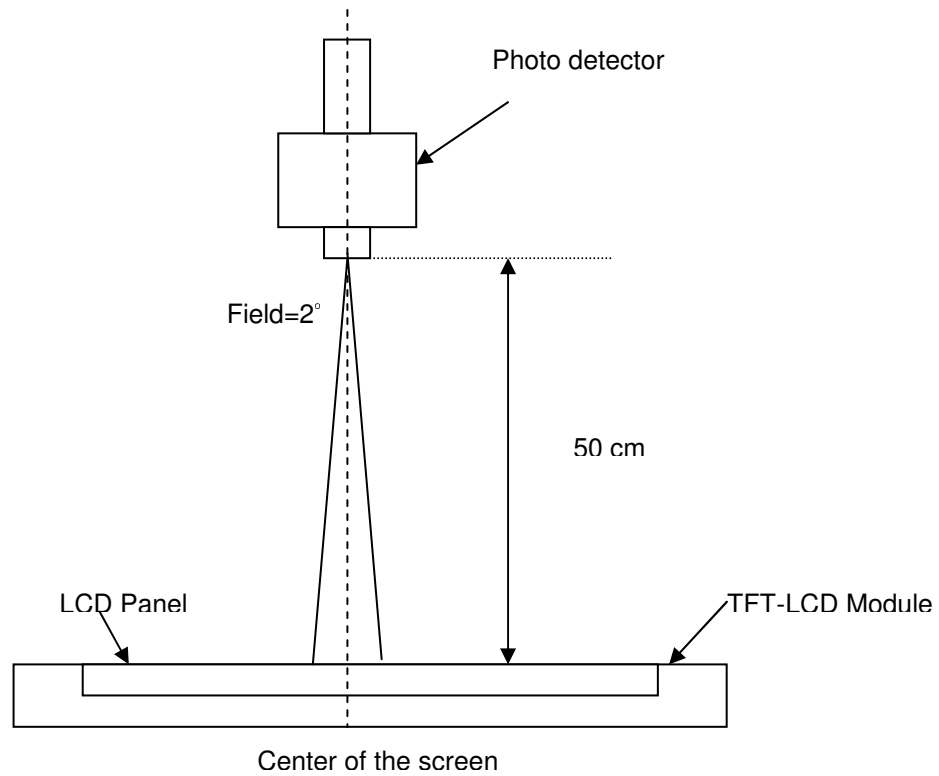

Note 5 : Definition of Average Luminance of White (Y_L):

Measure the luminance of gray level 63 at 5 points , $Y_L = [L (1)+ L (2)+ L (3)+ L (4)+ L (5)] / 5$

$L (x)$ is corresponding to the luminance of the point X at Figure in Note (1).

Note 6 : Definition of contrast ratio:

Contrast ratio is calculated with the following formula.

$$\text{Contrast ratio (CR)} = \frac{\text{Brightness on the "White" state}}{\text{Brightness on the "Black" state}}$$

Note 7 : Definition of Cross Talk (CT)

$$CT = |Y_B - Y_A| / Y_A \times 100 (\%)$$

Where

Y_A = Luminance of measured location without gray level 0 pattern (cd/m^2)

Y_B = Luminance of measured location with gray level 0 pattern (cd/m^2)

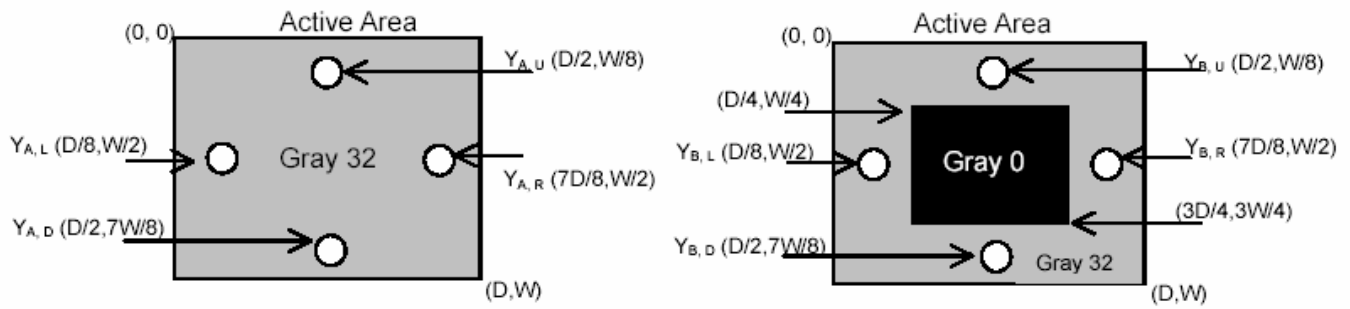

Note 8: Definition of response time:

The output signals of BM-7 or equivalent are measured when the input signals are changed from "Black" to "White" (falling time) and from "White" to "Black" (rising time), respectively. The response time interval between the 10% and 90% of amplitudes. Refer to figure as below.

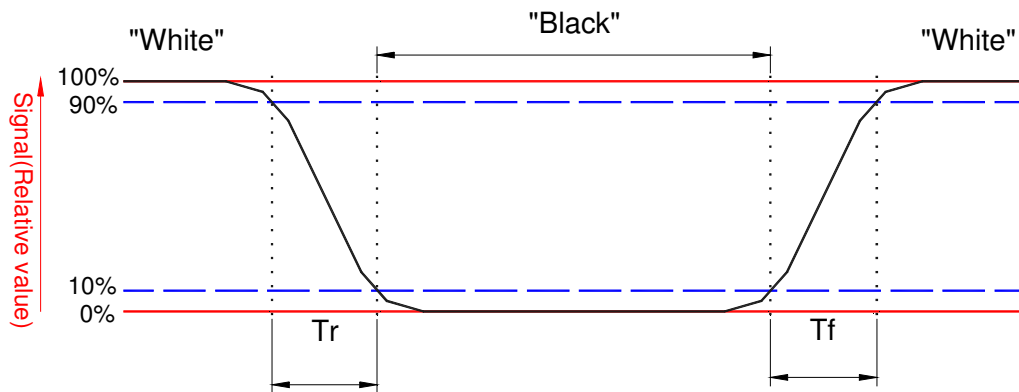

Note 9. Definition of viewing angle

Viewing angle is the measurement of contrast ratio ≥ 10 , at the screen center, over a 180° horizontal and 180° vertical range (off-normal viewing angles). The 180° viewing angle range is broken down as follows; 90° (θ) horizontal left and right and 90° (ϕ) vertical, high (up) and low (down). The measurement direction is typically perpendicular to the display surface with the screen rotated about its center to develop the desired measurement viewing angle.

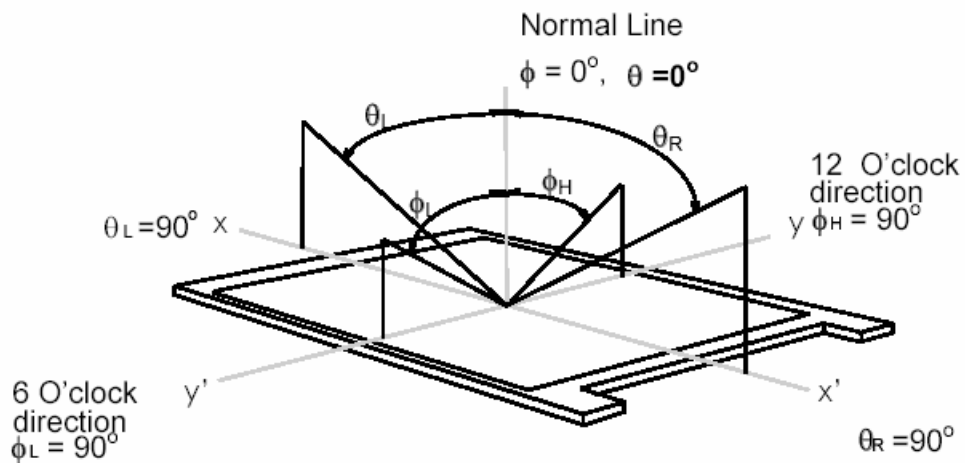

3. Functional Block Diagram

The following diagram shows the functional block of the 11.6 inches wide Color TFT/LCD 40 Pin one channel Module

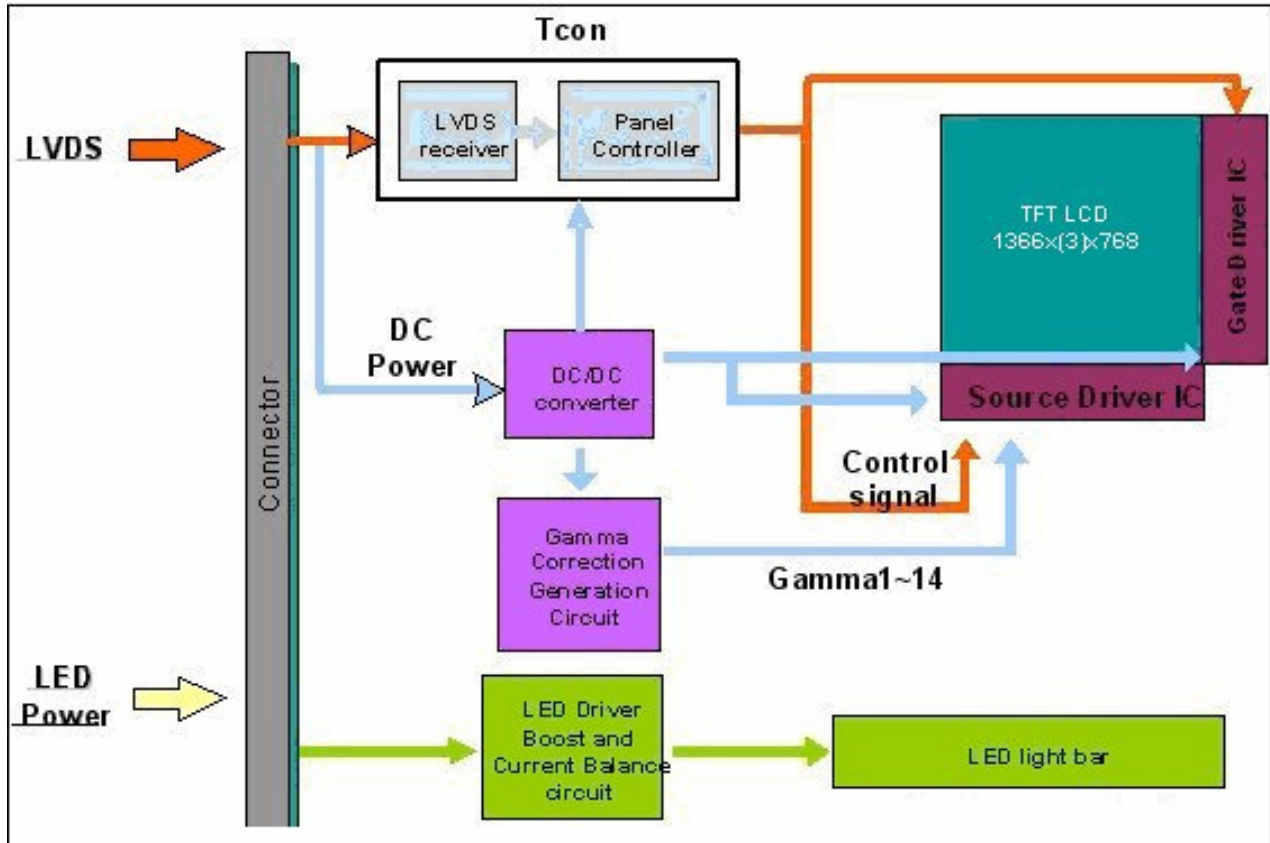

4. Absolute Maximum Ratings

An absolute maximum rating of the module is as following:

4.1 Absolute Ratings of TFT LCD Module

Item	Symbol	Min	Max	Unit	Conditions
Logic/LCD Drive Voltage	Vin	-0.3	+4.0	[Volt]	Note 1,2

4.2 Absolute Ratings of Environment

Item	Symbol	Min	Max	Unit	Conditions
Operating Temperature	TOP	0	+50	[°C]	Note 4
Operation Humidity	HOP	5	95	[%RH]	Note 4
Storage Temperature	TST	-20	+60	[°C]	Note 4
Storage Humidity	HST	5	95	[%RH]	Note 4

Note 1: At Ta (25°C)

Note 2: Permanent damage to the device may occur if exceed maximum values

Note 3: LED specification refer to section 5.2

Note 4: For quality performance, please refer to AUO IIS (Incoming Inspection Standard).

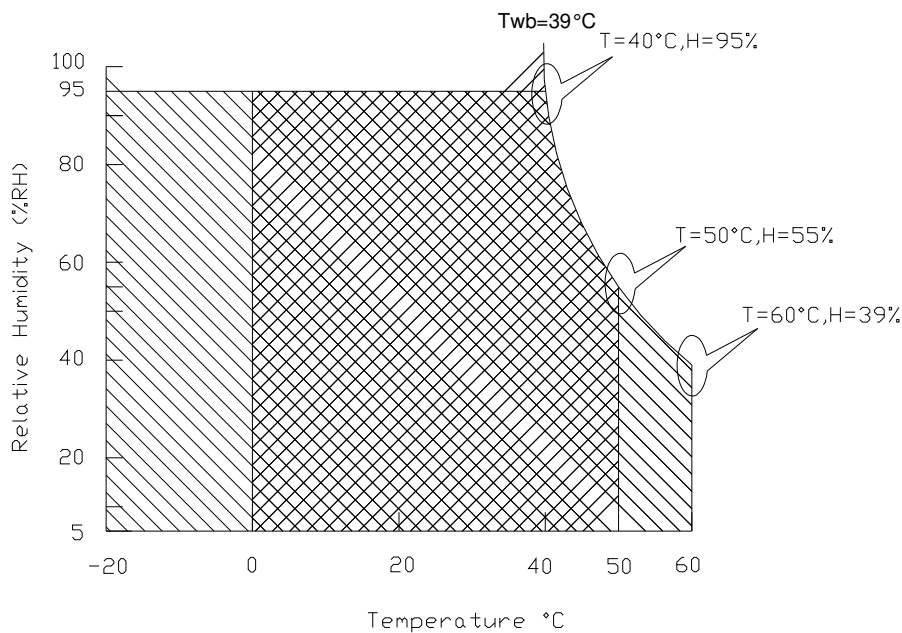

Operating Range

Storage Range +

5. Electrical Characteristics

5.1 TFT LCD Module

5.1.1 Power Specification

Input power specifications are as follows;

The power specification are measured under 25°C and frame frequency under 60Hz

Symble	Parameter	Min	Typ	Max	Units	Note
VDD	Logic/LCD Drive Voltage	3.0	3.3	3.6	[Volt]	
PDD	VDD Power	-	-	0.8	[Watt]	Note 1
IDD	IDD Current	-	-	242	[mA]	Note 1
IRush	Inrush Current	-	-	2000	[mA]	Note 2
VDDrp	Allowable Logic/LCD Drive Ripple Voltage	-	-	100	[mV] p-p	

Note 1 : Maximum Measurement Condition : Black Pattern at 3.3V driving voltage. ($P_{max} = V_{3.3} \times I_{black}$)

Note 2 : Measure Condition

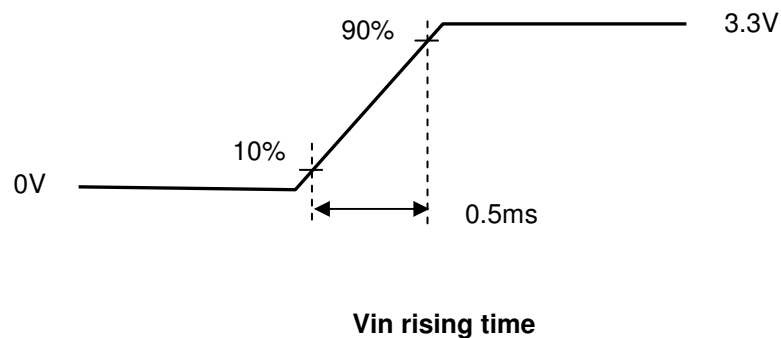
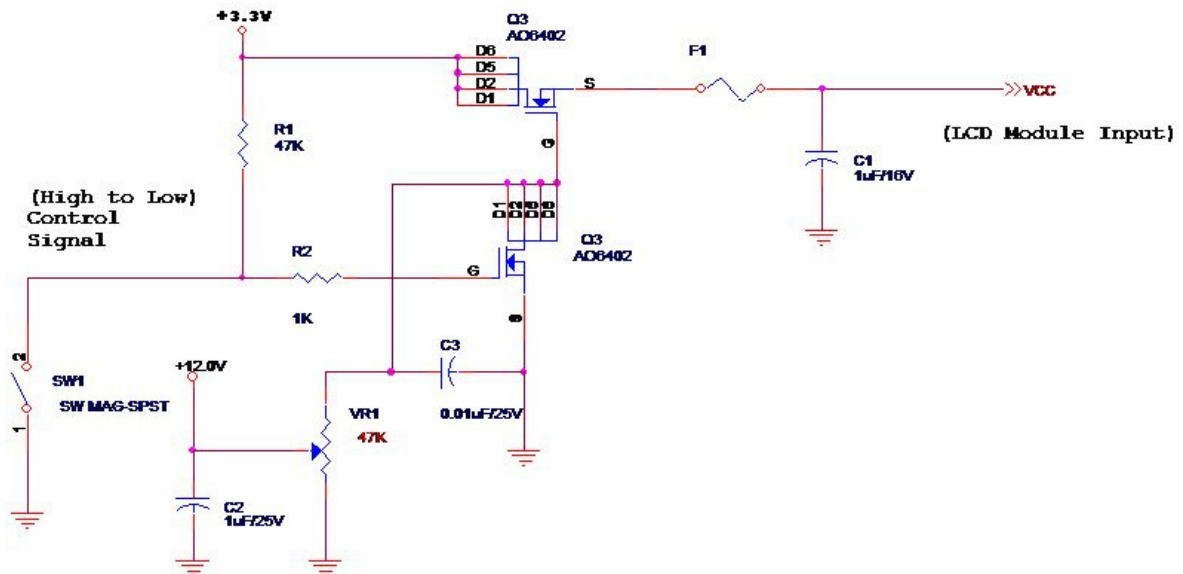

5.1.2 Signal Electrical Characteristics

Input signals shall be low or High-impedance state when VDD is off.

Signal electrical characteristics are as follows;

Parameter	Condition	Min	Max	Unit
V_{th}	Differential Input High Threshold ($V_{cm}=+1.2V$)		100	[mV]
V_{tl}	Differential Input Low Threshold ($V_{cm}=+1.2V$)	-100	-	[mV]
V_{ID}	Differential Input Voltage	100	600	[mV]
V_{cm}	Differential Input Common Mode Voltage	1.125	1.375	[V]

Note: LVDS Signal Waveform

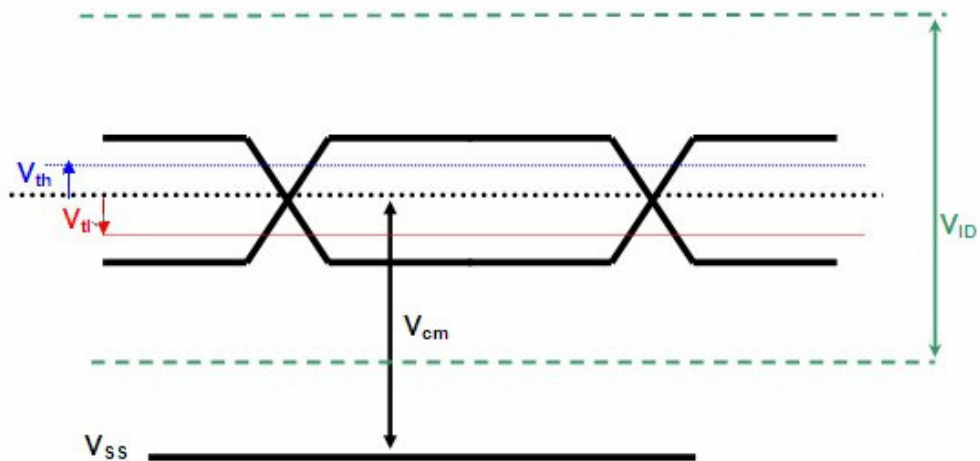

5.2 Backlight Unit

5.2.1 LED characteristics

Parameter	Symbol	Min	Typ	Max	Units	Condition
Backlight Power Consumption	PLED	-	-	2.08	[Watt]	(Ta=25°C), Note 1 Vin =12V
LED Life-Time	N/A	10,000	-	-	Hour	(Ta=25°C), Note 2 If=20 mA

Note 1: Calculator value for reference $P_{LED} = VF$ (Normal Distribution) * I_F (Normal Distribution) / Efficiency

Note 2: The LED life-time define as the estimated time to 50% degradation of initial luminous.

5.2.2 Backlight input signal characteristics

Parameter	Symbol	Min	Typ	Max	Units	Remark
LED Power Supply	VLED	6.0	12.0	21.0	[Volt]	Define as Connector Interface (Ta=25°C)
LED Enable Input High Level	VLED_EN	2.5	-	5.5	[Volt]	
LED Enable Input Low Level		-	-	0.8	[Volt]	
PWM Logic Input High Level	VPWM_EN	2.5	-	5.5	[Volt]	
PWM Logic Input Low Level		-	-	0.8	[Volt]	
PWM Input Frequency	FPWM	900	-	1.1k	Hz	
PWM Duty Ratio	Duty	5	--	100	%	

6.2 The Input Data Format

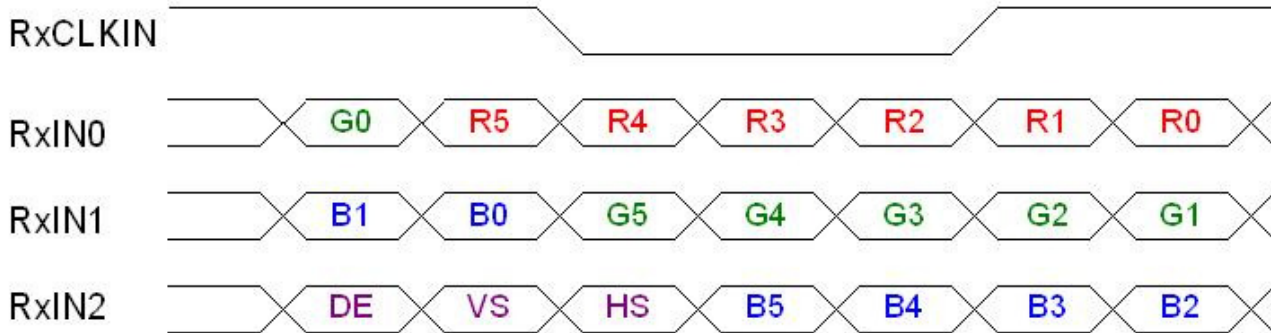

Signal Name	Description	
R5 R4 R3 R2 R1 R0	Red Data 5 (MSB) Red Data 4 Red Data 3 Red Data 2 Red Data 1 Red Data 0 (LSB)	Red-pixel Data Each red pixel's brightness data consists of these 6 bits pixel data.
G5 G4 G3 G2 G1 G0	Green Data 5 (MSB) Green Data 4 Green Data 3 Green Data 2 Green Data 1 Green Data 0 (LSB)	Green-pixel Data Each green pixel's brightness data consists of these 6 bits pixel data.
B5 B4 B3 B2 B1 B0	Blue Data 5 (MSB) Blue Data 4 Blue Data 3 Blue Data 2 Blue Data 1 Blue Data 0 (LSB)	Blue-pixel Data Each blue pixel's brightness data consists of these 6 bits pixel data.
RxCLKIN	Data Clock	The signal is used to strobe the pixel data and DE signals. All pixel data shall be valid at the falling edge when the DE signal is high.
DE	Display Timing	This signal is strobed at the falling edge of RxCLKIN. When the signal is high, the pixel data shall be valid to be displayed.
VS	Vertical Sync	The signal is synchronized to RxCLKIN .
HS	Horizontal Sync	The signal is synchronized to RxCLKIN .

Note: Output signals from any system shall be low or High-impedance state when VDD is off.

6.3 Integration Interface Requirement

6.3.1 Connector Description

Physical interface is described as for the connector on module.

These connectors are capable of accommodating the following signals and will be following components.

Connector Name / Designation	For Signal Connector
Manufacturer	IPEX or compatible
Type / Part Number	IPEX 20455-040E-12 or compatible
Mating Housing/Part Number	IPEX 20353-040T-11 or compatible

6.3.2 Pin Assignment

LVDS is a differential signal technology for LCD interface and high speed data transfer device.

PIN#	Signal Name	Description
1	NC	No Connection (Reserve)
2	VDD	Power Supply +3.3V
3	VDD	Power Supply +3.3V
4	VEDID	EDID +3.3V Power
5	NC	No Connect (Reserve)
6	CLK_EDID	EDID Clock Input
7	DAT_EDID	EDID Data Input
8	RxOIN0-	-LVDS Differential Data INPUT(Odd R0-R5,G0)
9	RxOIN0+	+LVDS Differential Data INPUT(Odd R0-R5,G0)
10	VSS	Ground
11	RxOIN1-	-LVDS Differential Data INPUT(Odd G1-G5,B0-B1)
12	RxOIN1+	+LVDS Differential Data INPUT(Odd G1-G5,B0-B1)
13	VSS	Ground
14	RxOIN2-	-LVDS Differential Data INPUT(Odd B2-B5,HS,VS,DE)
15	RxOIN2+	+LVDS Differential Data INPUT(Odd B2-B5,HS,VS,DE)
16	VSS	Ground
17	RxOCKIN-	-LVDS Odd Differential Clock INPUT
18	RxOCKIN+	-LVDS Odd Differential Clock INPUT
19	IMG_EN	Color Matrix Enable (3.0V~3.6V,3.3V type)
20	NC	No connection
21	NC	No connection
22	NC	No connection

23	NC	No connection
24	NC	No connection
25	NC	No connection
26	NC	No connection
27	NC	No connection
28	NC	No connection
29	NC	No connection
30	NC	No connection
31	VLED_GND	LED Ground
32	VLED_GND	LED Ground
33	VLED_GND	LED Ground
34	NC	No Connection (Reserve)
35	VPWM_EN	PWM logic input level
36	VLED_EN	LED enable input level
37	DCR_EN	DCR Enable(3.0V~3.6V, 3.3V type)
38	VLED	LED Power Supply
39	VLED	LED Power Supply
40	VLED	LED Power Supply

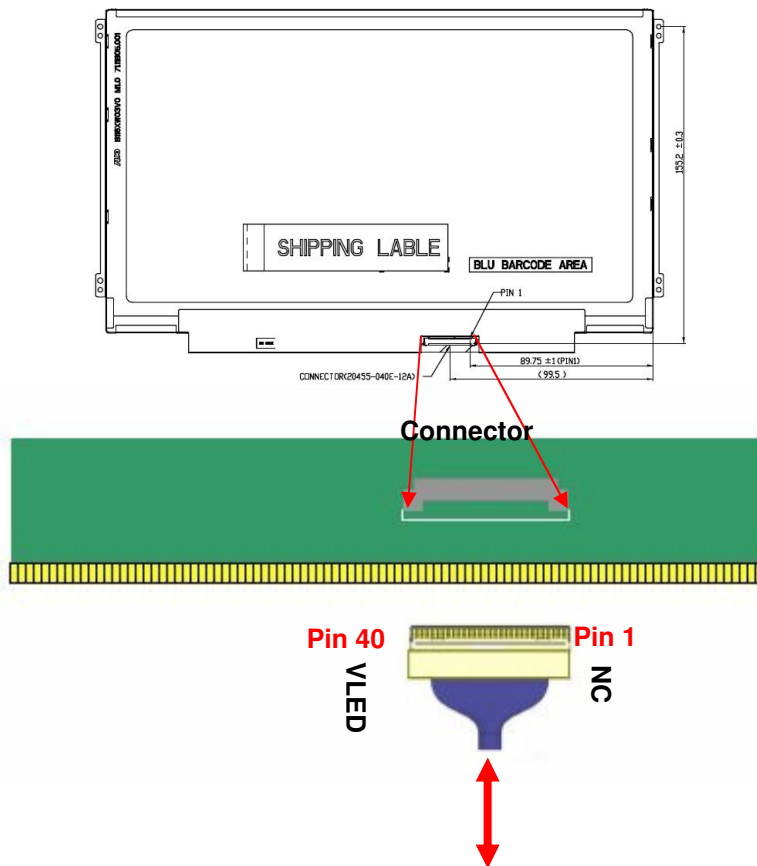

Note1: Input signals shall be low or High-impedance state when VDD is off.

6.4 Interface Timing

6.4.1 Timing Characteristics

Basically, interface timings should match the 1366x768 /60Hz manufacturing guide line timing.

Parameter	Symbol	Min.	Typ.	Max.	Unit	
Frame Rate	-		60	-	Hz	
Clock frequency	$1/T_{\text{Clock}}$	65	69.3	80	MHz	
Vertical Section	Period	T_V	776	793	1000	T_{Line}
	Active	T_{VD}	768			
	Blanking	T_{VB}	8	25	180	
Horizontal Section	Period	T_H	1396	1456	2000	T_{Clock}
	Active	T_{HD}	1366			
	Blanking	T_{HB}	30	90	634	

Note : DE mode only

6.4.2 Timing diagram

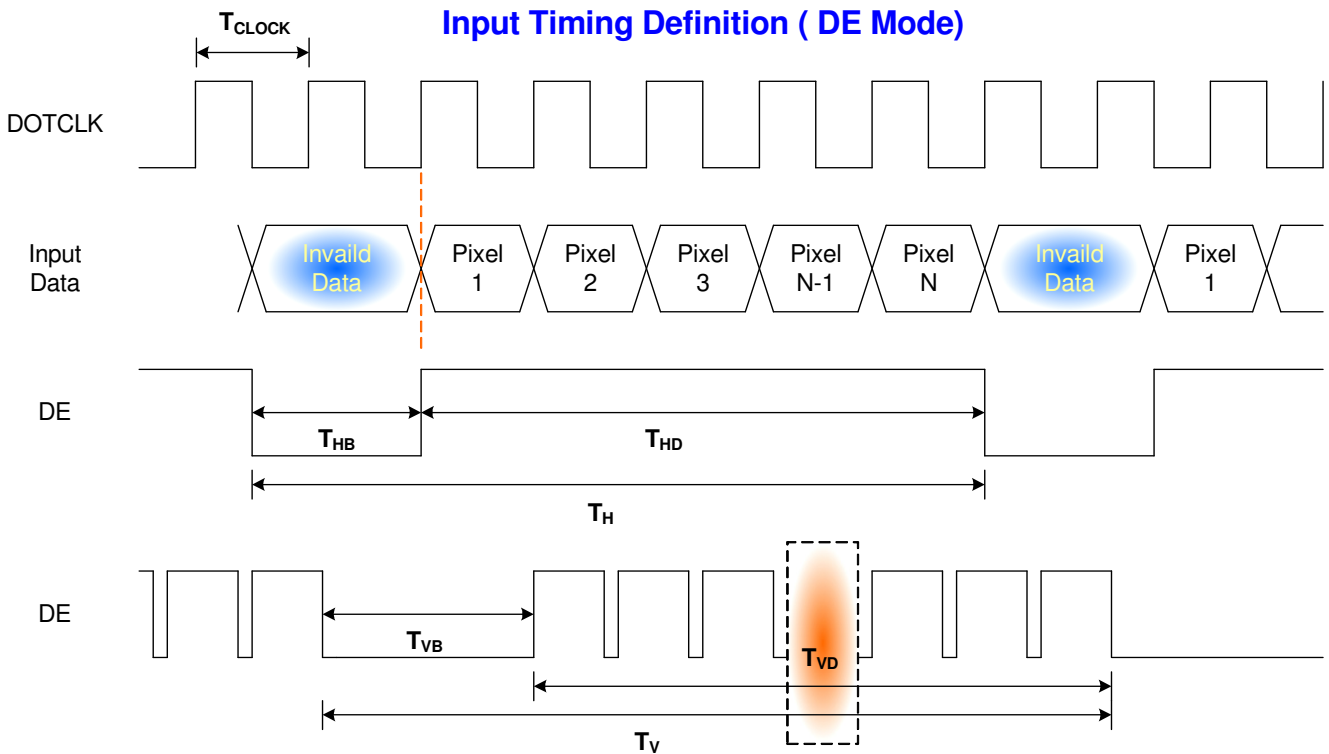

6.5 Power ON/OFF Sequence

Power on/off sequence is as follows. Interface signals and LED on/off sequence are also shown in the chart. Signals from any system shall be Hi-Z state or low level when VDD is off

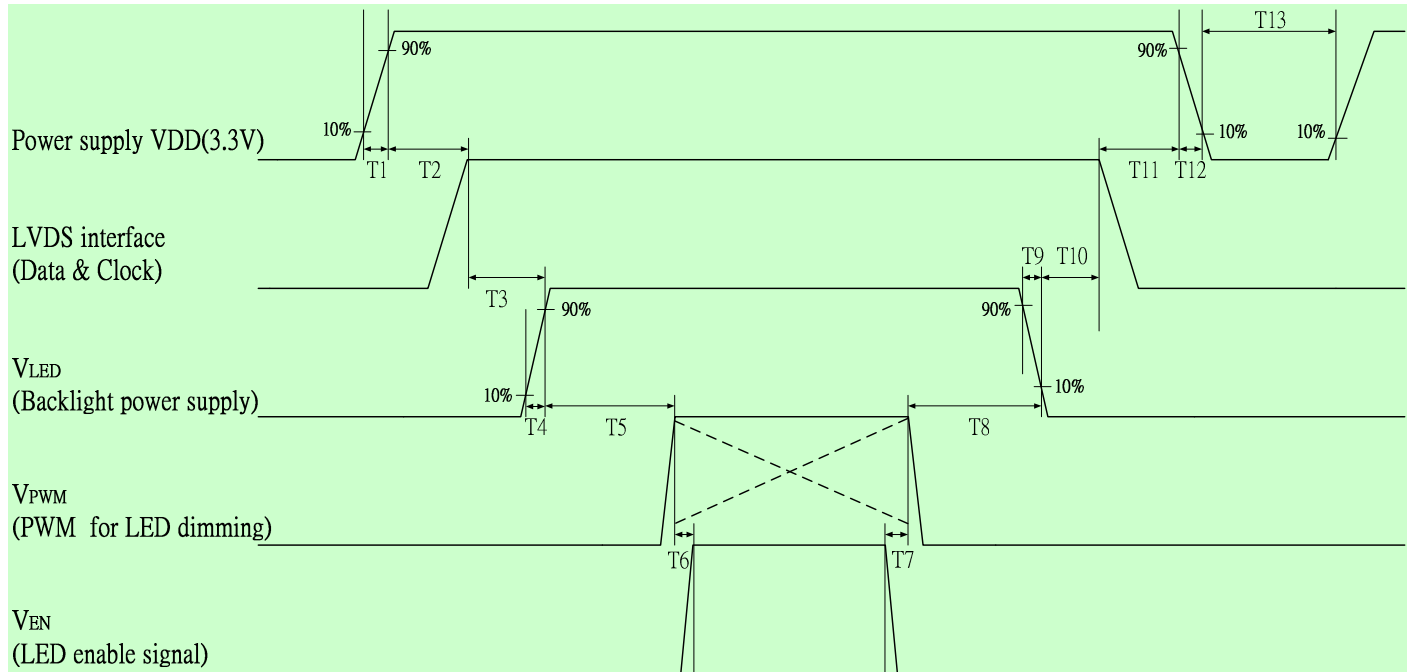

Power Sequence Timing				
Parameter	Value			Units
	Min.	Typ.	Max.	
T1	0.5	-	10	ms
T2	0	-	50	
T3	200	-	-	
T4	0.5	-	10	
T5	10	-	-	
T6	10	-	-	
T7	0	-	-	
T8	10	-	-	
T9	0	-	10	
T10	200	-	-	
T11	0.5	-	50	
T12	0	-	10	
T13	400	-	-	

Note: If T3, T5, T6 couldn't match above specifications, must request $T3+T5+T6 > 200\text{ms}$ at least

7. Panel Reliability Test

7.1 Vibration Test

Test Spec:

- Test method: Non-Operation
- Acceleration: 1.5 G
- Frequency: 10 - 500Hz Random
- Sweep: 30 Minutes each Axis (X, Y, Z)

7.2 Shock Test

Test Spec:

- Test method: Non-Operation
- Acceleration: 220 G , Half sine wave
- Active time: 2 ms
- Pulse: X,Y,Z .one time for each side

7.3 Reliability Test

Items	Required Condition	Note
Temperature Humidity Bias	Ta= 40°C, 90%RH, 300h	
High Temperature Operation	Ta= 50°C, Dry, 300h	
Low Temperature Operation	Ta= 0°C, 300h	
High Temperature Storage	Ta= 60°C, 35%RH, 300h	
Low Temperature Storage	Ta= -20°C, 50%RH, 250h	
Thermal Shock Test	Ta=-20°C to 60°C, Duration at 30 min, 100 cycles	
ESD	Contact : ±8 KV Air : ±15 KV	Note 1

Note1: According to EN 61000-4-2 , ESD class B: Some performance degradation allowed. No data lost
 . Self-recoverable. No hardware failures.

Remark: MTBF (Excluding the LED): 30,000 hours with a confidence level 90%

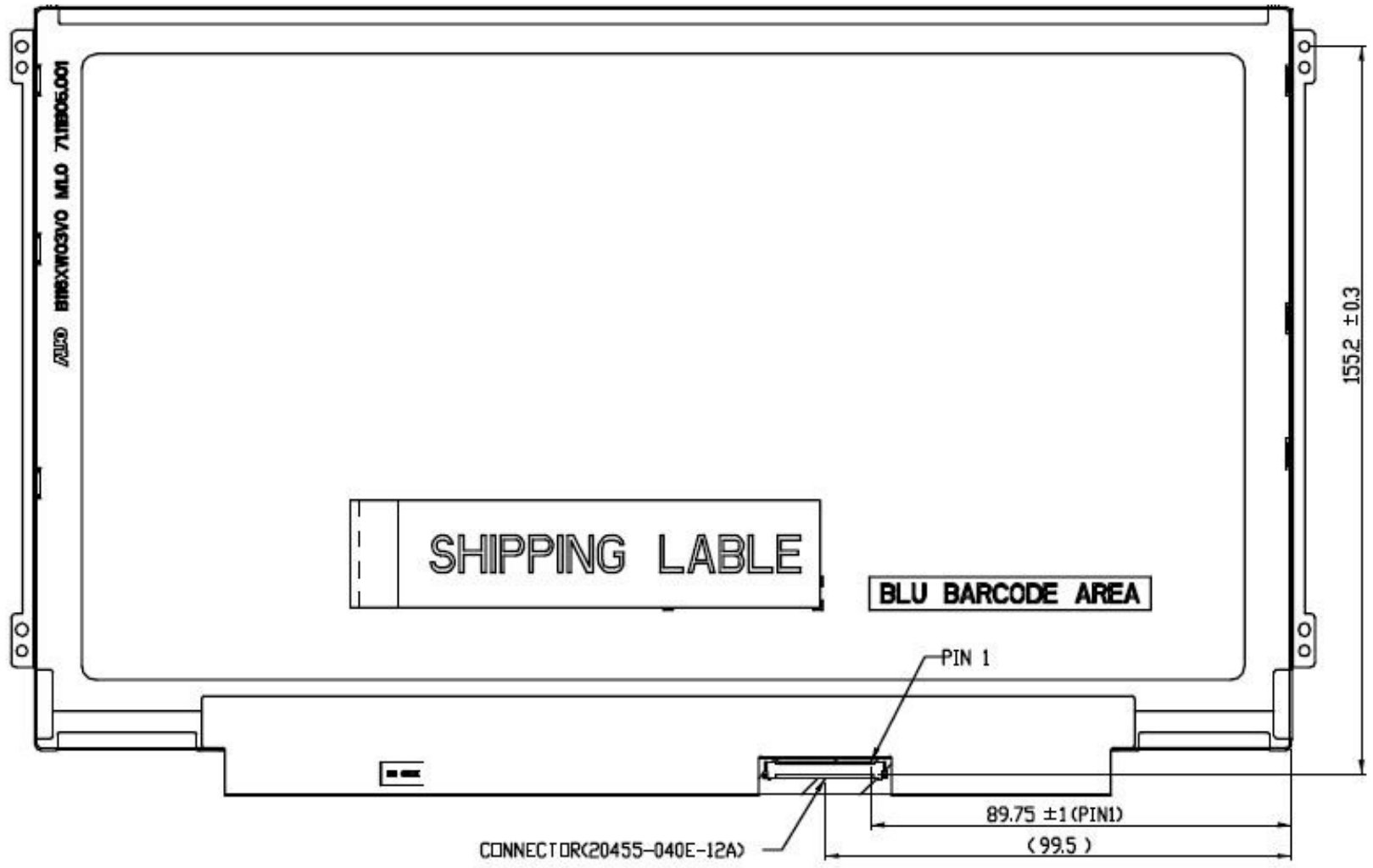

Note: Prevention IC damage, IC positions not allowed any overlap over these areas.



9. Shipping and Package

9.1 Shipping Label Format

(TBD)

9.2 Carton Package

The outside dimension of carton is 469(L)mm* 378(W)mm* 266(H)mm

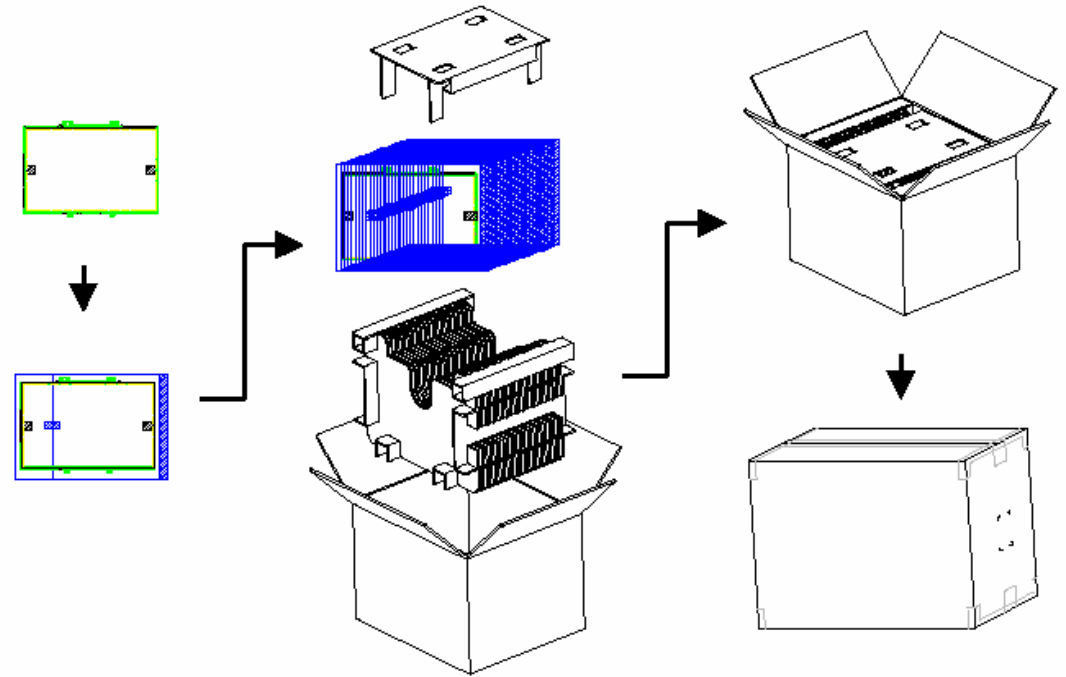

9.3 Shipping Package of Palletizing Sequence

