

TCC-202

Two-Output PTIC Control IC

Introduction

TCC-202 is a two-output high-voltage digital to analog control IC specifically designed to control and bias ON Semiconductor's Passive Tunable Integrated Circuits (PTICs).

These tunable capacitor control circuits are intended for use in mobile phones and dedicated RF tuning applications. The implementation of ON Semiconductor's tunable circuits in mobile phones enables significant improvement in terms of antenna radiated performance.

The tunable capacitors are controlled through a bias voltage ranging from 1 V to 24 V. The TCC-202 high-voltage PTIC control IC has been specifically designed to cover this need, providing two independent high-voltage outputs that control up to two different tunable PTICs in parallel. The device is fully controlled through a MIPI interface.

Key Features

- Controls ON Semiconductor's PTIC Tunable Capacitors
- Compliant with Timing Needs of Cellular and Other Wireless System Requirements
- Integrated Boost Converter with 2 Programmable DAC Outputs (up to 24 V)
- Low Power Consumption
- MIPI-RFFE Interface
- Compliant with MIPI 26 MHz Read-back
- Available in WLCSP (RDL ball arrays)
- This is a Pb-Free Device

Typical Applications

- Multi-band, Multi-standard, Advanced and Simple Mobile Phones
- Tunable Antenna Matching Networks
- Compatible with Closed-loop and Open-loop Antenna Tuner Applications



ON Semiconductor®

www.onsemi.com



**WLCSP12
CASE 567KZ**

MARKING DIAGRAM



- A = Assembly Location
- L = Wafer Lot
- Y = Year
- W = Work Week
- = Pb-Free Package

ORDERING INFORMATION

See detailed ordering and shipping information on page 21 of this data sheet.

TCC-202

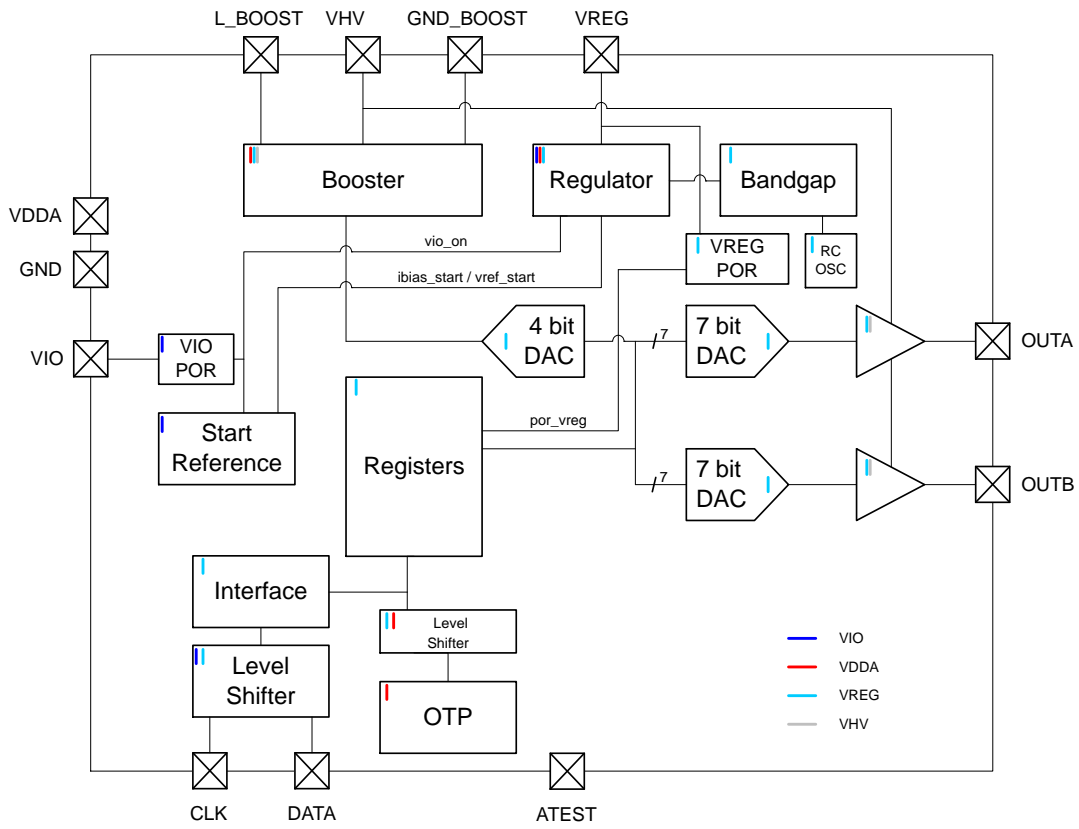

Figure 1. Control IC Functional Block Diagram

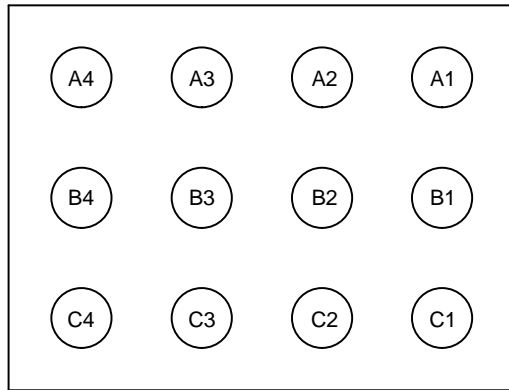

Figure 2. Die Bump Side View

TCC-202

RDL Pin Out

Table 1. PAD DESCRIPTIONS

Bump RDL	Name	Type	Description	Max Voltage
A1	OUTB	AOH	High Voltage Output B	VHV
A2	ATEST	AO	Analog Test Out (Note 1)	VREG
A3	VHV	AOH/AIH	Boost High Voltage	28
A4	L_BOOST	AOH	Boost Inductor	28
B1	OUTA	AOH	High Voltage Output A	VHV
B2	GNDA	P	Analog Ground	0
B3	GND_BOOST	P	Ground for Booster	0
B4	VIO		Digital IO Supply	2
C1	VREG	AO	Regulator Output	2
C2	AVDD		Analog Supply	5.5
C3	DATA	DIO	MIPI RFFE Data	VIO
C4	CLK	DI	MIPI RFFE Clock	VIO

1. To be grounded when not in use.

ELECTRICAL PERFORMANCE SPECIFICATIONS

Table 2. ABSOLUTE MAXIMUM RATINGS

Symbol	Parameter	Rating	Unit
AVDD	Analog Supply Voltage	-0.3 to +6.0	V
VIO	IO Reference Supply Voltage	-0.3 to +2.2	V
V _{I/O}	Input Voltage Logic Lines (DATA, CLK, CS)	-0.3 to VIO + 0.3	V
V _{HVH}	VHV Maximum Voltage	-0.3 to 30	V
V _{ESD (HBM)}	Human Body Model, JESD22-A114, All I/O	2,000	V
V _{ESD (MM)}	Machine Model, JESD22-A115	200	V
T _{STG}	Storage Temperature	-55 to +150	°C
T _{AMB_OP_MAX}	Max Operating Ambient Temperature without Damage	+110	°C

Stresses exceeding those listed in the Maximum Ratings table may damage the device. If any of these limits are exceeded, device functionality should not be assumed, damage may occur and reliability may be affected.

TCC-202

Table 3. RECOMENDED OPERATING CONDITIONS

Symbol	Parameter	Rating			Unit
		Min	Typ	Max	
T _{AMB_OP}	Operating Ambient Temperature	-30	-	+85	°C
T _{J_OP}	Operating Junction Temperature	-30	-	+125	°C
AVDD	Analog Supply Voltage	2.3	-	5.5	V
VIO	IO Reference Supply Voltage	1.62	-	1.98	V

Table 4. DC CHARACTERISTICS (T_A = -30 to +85°C; V_{OUTX} = 15 V for each output; 2.3 V < AVDD < 5.5 V; 1.62 V < VIO < 1.98 V; R_{LOAD} = equivalent series load of 5.6 kΩ and 2.7 nF; C_{HV} = 47 nF; L_{BOOST} = 15 μH; unless otherwise specified)

Symbol	Parameter	Min	Typ	Max	Unit	Comment
--------	-----------	-----	-----	-----	------	---------

SHUTDOWN MODE

I _{AVDD}	AVDD Supply Current	-	-	1.5	μA	VIO Supply is Low
I _{L_BOOST}	L_BOOST Leakage	-	-	1.5		
I _{BATT}	Battery Current	-	-	2.5		
I _{VIO}	VIO Supply Current	-1	-	1		
I _{CLK}	CLK Leakage	-1	-	1		
I _{DATA}	DATA Leakage	-1	-	1		

ACTIVE MODE

I _{BATT_SS0}	Average battery current, 2 outputs @ 0 V steady state	-	380	750	μA	At VHV = 20 V AVDD = 3.3 V
I _{BAT_SS2}	Average battery current, 2 outputs @ 2 V steady state	-	400	780		At VHV = 20 V AVDD = 3.3 V
I _{BATT_SS16}	Average battery current, 2 outputs @ 16 V steady state	-	510	870		At VHV = 20 V AVDD = 3.3 V
I _{L_BOOST_SS0}	Average inductor current, 2 outputs @ 0 V steady state	-	260	490		At VHV = 20 V AVDD = 3.3 V
I _{L_BOOST_SS2}	Average inductor current, 2 outputs @ 2 V steady state	-	280	510		At VHV = 20 V AVDD = 3.3 V
I _{L_BOOST_SS16}	Average inductor current, 2 outputs @ 16 V steady state	-	400	600		At VHV = 20 V AVDD = 3.3 V
I _{VIO_INACT}	VIO average inactive current	-	-	3		VIO is high, no bus activity
I _{VIO_ACTIVE}	VIO average active current	-	-	250		VIO = 1.8 V, master sending data at 26 MHz
V _{VREG}		1.7	-	1.9	V	No external load allowed

LOW POWER MODE

I _{AVDD}	AVDD Supply Current	-	-	8	μA	
I _{L_BOOST}	L_BOOST Leakage	-	-	6		
I _{BATT}	Battery Current	-	-	14		I _{AVDD} + I _{L_BOOST}
I _{VIO}	VIO Supply Current	-	-	3		No bus activity
V _{VREG}		1.6	-	1.9	V	No external load allowed

TCC-202

Table 5. BOOST CONVERTER CHARACTERISTICS

(AVDD from 2.3 V to 5.5 V; VIO from 1.62 V to 1.98 V; $T_A = -30$ to $+85^\circ\text{C}$; $C_{HV} = 47$ nF; $L_{BOOST} = 15$ μH ; unless otherwise specified)

Symbol	Parameter	Conditions	Min	Typ	Max	Unit
VHV_min	Minimum programmable output voltage (average), DAC Boost = 0h	Active mode	–	13	–	V
VHV_max	Maximum programmable output voltage (average), DAC Boost = Fh	Active mode	–	28	–	
Resolution	Boost voltage resolution	4-bit DAC	–	1	–	
$I_{L_BOOST_LIMIT}$	Inductor current limit		–	200	–	mA

Table 6. ANALOG OUTPUTS (OUT A, OUT B)

(AVDD from 2.3 V to 5.5 V; VIO from 1.62 V to 1.98 V; VHV = 26 V; $T_A = -30$ to $+85^\circ\text{C}$; $R_{load} = \infty$ unless otherwise specified)

Parameter	Description	Min	Typ	Max	Unit	Comment
-----------	-------------	-----	-----	-----	------	---------

SHUTDOWN MODE

Z_{OUT}	OUT A, OUT B output impedance	7	–	–	$M\Omega$	DAC disabled
-----------	-------------------------------	---	---	---	-----------	--------------

ACTIVE MODE

V_{OH}	Maximum output voltage	–	23.8	–	V	DAC A, B = 7Fh, DAC Boost = Fh, $I_{OH} < 10$ μA
V_{OL}	Minimum output voltage	–	–	1	V	DAC A, B = 01h, DAC Boost = 0h to Fh, $I_{OH} < 10$ μA
Slew Rate		–	3	10	μs	2 V to 24 V step, measured at $V_{OUT} = 15.2$ V, $R_{LOAD} =$ equivalent series load of 2.7 k Ω and 5.6 nF, Turbo enabled
R_{PD}	OUT A, OUT B set in pull-down mode	–	–	1000	Ω	DAC A, B = 00h, DAC Boost = 0h to Fh, selected output(s) is disabled
Resolution	Voltage resolution (1-bit)	–	188	–	mV	(1 LSB = 1-bit)
V_{OFFSET}	Zero scale, least squared best fit	–1	–	+1	LSB	
Error		–3.0	–	+3.0	$\%V_{OUT}$	Over 2 V – 24 V V_O range
DNL	Differential non-linearity least squared best fit	–0.9	–	+0.9	LSB	Over 2 V – 24 V V_O range
INL	Integral non-linearity least squared best fit	–1	–	+1	LSB	Over 2 V – 24 V V_O range
I_{SC}	Over current protection	–	5	65	mA	Any DAC output shorted to ground
V_{RIPPLE}	Output ripple with all outputs at steady state	–	–	40	mV RMS	Over 2 V – 24 V for VHV = 23.5 V

THEORY OF OPERATION

Overview

The control IC outputs are directly controlled by programming the two DACs (DAC A and DAC B) through the digital interface.

The DAC stages are driven from a reference voltage, generating an analog output voltage driving a high-voltage amplifier supplied from the boost converter (see Figure 1 – Control IC Functional Block Diagram).

The control IC output voltages are scaled from 0 V to 24 V, with 128 steps of 188 mV ($2 \times (24 / 255 \text{ V}) = 0.188235 \text{ V}$). The nominal control IC output can be approximated to $188 \text{ mV} \times \text{DAC value}$.

For performance optimization the boost output voltage (VHV) can be programmed to levels between 13 V and 28 V via the DAC_boost register (4 bits with 1 V steps). The startup default level for the boosted voltage is $VHV = 24 \text{ V}$.

For proper operation and to avoid saturation of the output devices and noise issues it is recommended to operate the boosted VHV voltage at least 2 V above the highest programmed V_{OUT} voltage of any of the two outputs.

Operating Modes

The following operating modes are available:

1. **Shutdown Mode:** All circuit blocks are off, the DAC outputs are disabled and placed in high Z state and current consumption is limited to minimal leakage current. The shutdown mode is entered upon initial application of AVDD or upon VIO being placed in the low state. The contents of the registers are not maintained in shutdown mode.
2. **Startup Mode:** Startup is only a transitory mode. Startup mode is entered upon a VIO high state. In

startup mode all registers are reset to their default states, the digital interface is functional, the boost converter is activated, outputs OUT A and OUT B are disabled and the DAC outputs are placed in a high Z state. Control software can request a full hardware and register reset of the TCC-202 by sending an appropriate PWR_MODE command to direct the chip from either the active mode or the low power mode to the startup mode. From the startup mode the device automatically proceeds to the active mode.

3. **Active Mode:** All blocks of the TCC-202 are activated and the DAC outputs are fully controlled through the digital interface, DACs remain off until enabled. The DAC settings can be dynamically modified and the HV outputs will be adjusted according to the specified timing diagrams. Each DAC can be individually controlled and/or switched off according to application requirements. Active mode is automatically entered from the startup mode. Active mode can also be entered from the low power mode under control software command.
4. **Low Power Mode:** In low power mode the serial interface stays enabled, the DAC outputs are disabled and are placed in a high Z state and the boost voltage circuit is disabled. Control software can request to enter the low power mode from the active mode by sending an appropriate PWR_MODE command. The contents of all registers are maintained in the low power mode.

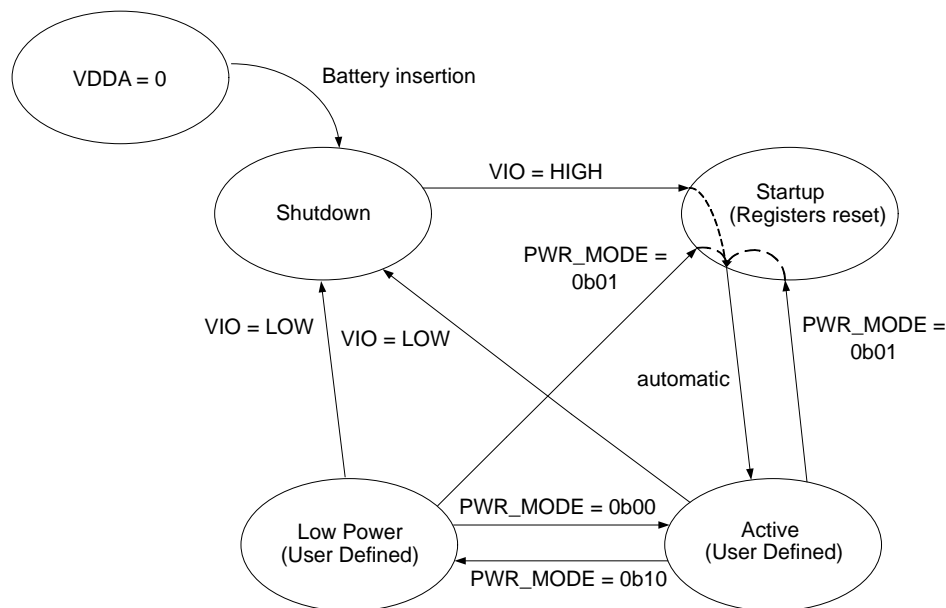

Figure 3. Modes of Operation

TCC-202

AVDD Power-On Reset (POR)

Upon application of AVDD the TCC-202 will be in shutdown mode. All circuit blocks are off and the chip draws only minimal leakage current.

VIO Power-On Reset and Startup Conditions

A high level on VIO places the chip in startup mode which provides a POR to the TCC-202. POR resets all registers to their default settings as described in Table 8. VIO POR also resets the serial interface circuitry. POR is not a brown-out detector and VIO needs to be brought back to a low level to enable the POR to trigger again.

Table 7. VIO POWER-ON RESET AND STARTUP

Register	Default State for VIO POR	Comment
DAC Boost	[1011]	VHV = 24 V
Power Mode	[01]>[00]	Transitions from shutdown to startup and then automatically to active mode
DAC Enable	[000000]	V _{OUT} A, B Disabled
DAC A		Output in High-Z Mode
DAC B		Output in High-Z Mode

VIO Shutdown

A low level at any time on VIO places the chip in shutdown mode in which all circuit blocks are off. The contents of the registers are not maintained in shutdown mode.

Table 8. VIO THRESHOLDS (AVDD from 2.3 V to 5.5 V; T_A = -30 to +85°C unless otherwise specified)

Parameter	Description	Min	Typ	Max	Unit	Comments
VIORST	VIO Low Threshold	-	-	0.2	V	When VIO is lowered below this threshold level the chip is reset and placed into the shutdown state

Power Supply Sequencing

The AVDD input is typically directly supplied from the battery and thus is the first on. After AVDD is applied and before VIO is applied to the chip, all circuits are in the shutdown state and draw minimum leakage currents. Upon application of VIO, the chip automatically starts up using default settings and is placed in the active state waiting for a command via the serial interface.

Table 9. TIMING (AVDD from 2.3 V to 5.5 V; VIO from 1.62 V to 1.98 V; T_A = -30 to +85°C; OUT A and OUT B; CHV = 47 nF; L_{BOOST} = 15 μH; VHV = 24 V; Turbo-Charge mode off unless otherwise specified; VDDA = 1.7 V)

Parameter	Description	Min	Typ	Max	Unit	Comments
T _{POR_VREG}	Internal bias settling time from shutdown to active mode	-	50	120	μs	For info only
T _{BOOST_START}	Time to charge CHV @ 80% of set VHV (set to 24 V, V _{DDA} = 2.7 V)	-	130	-	μs	For info only
T _{SD_TO_ACT}	Startup time from shutdown to active mode	-	180	300	μs	
T _{SET+}	Output A, B positive settling time to within 5% of the delta voltage, equivalent series load of 5.6 kΩ and 2.7 nF, V _{OUT} from 2 V to 20 V; 0Bh (11d) to 55h (85d)	-	50	60	μs	Voltage settling time connected on V _{OUT} A, B
T _{SET-}	Output A, B negative settling time to within 5% of the delta voltage, equivalent series load of 5.6 kΩ and 2.7 nF, V _{OUT} from 20 V to 2 V; 55h (85d) to 0Bh (11d)	-	50	60	μs	Voltage settling time connected on V _{OUT} A, B
T _{SET+}	Output A, B positive settling time with Turbo	-	35	-	μs	Voltage settling time connected on V _{OUT} A, B
T _{SET-}	Output A, B negative settling time with Turbo	-	35	-	μs	Voltage settling time connected on V _{OUT} A, B

TCC-202

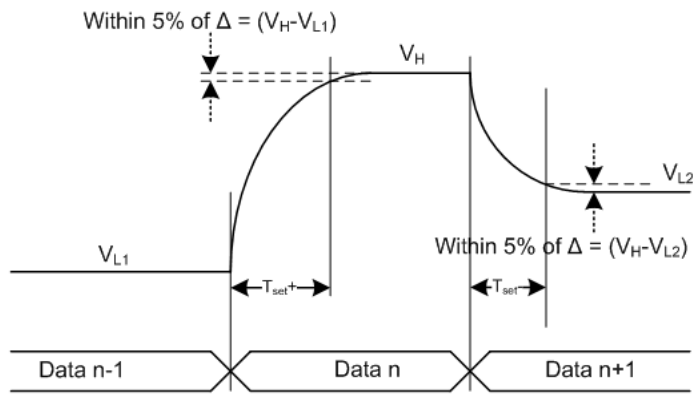

Figure 4. Output Settling Diagram

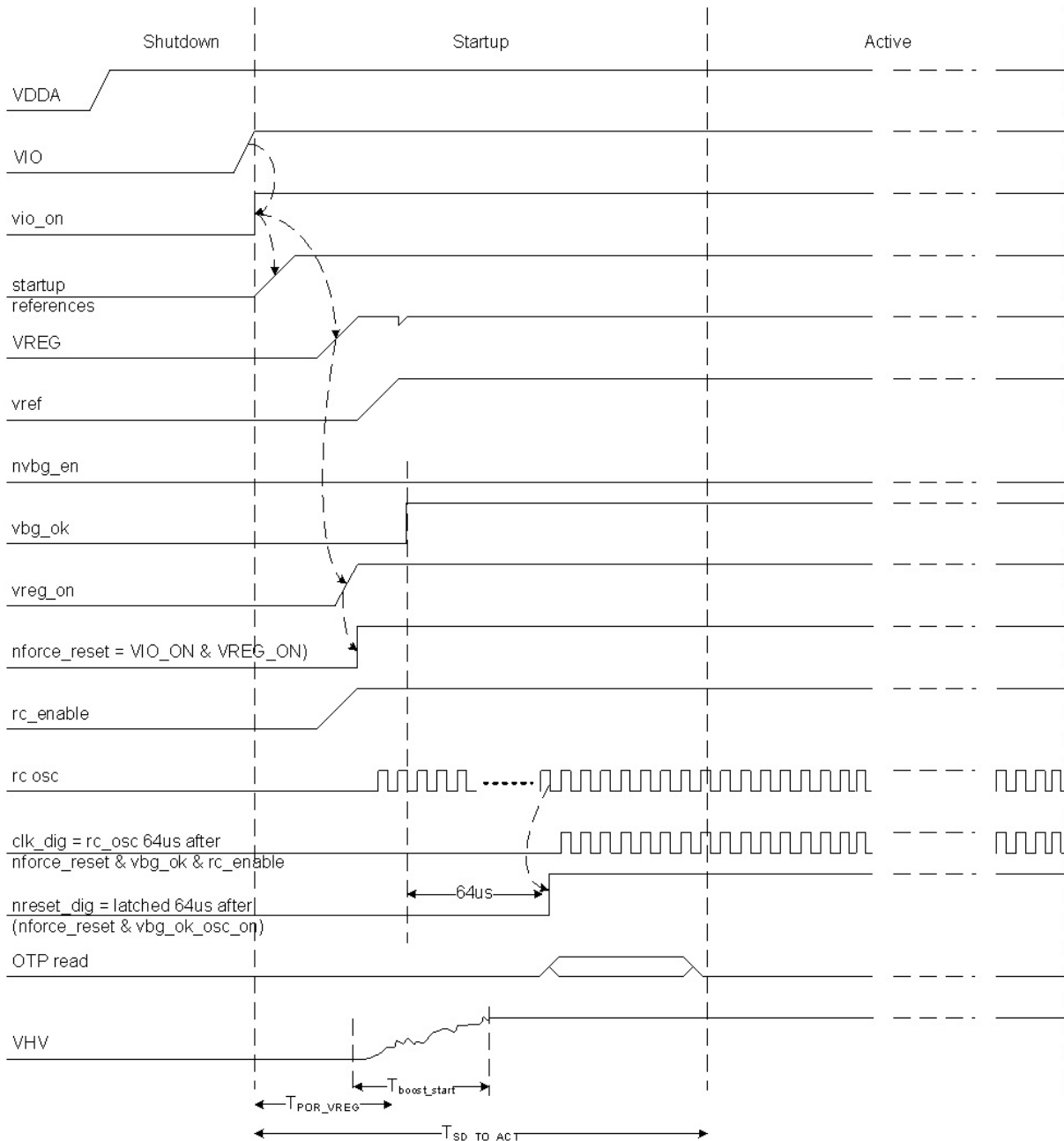

Figure 5. Startup Timing Diagram

Boost Control

The TCC-202 integrates an asynchronous current control boost converter. It operates in a discontinuous mode and features spread-spectrum circuitry for Electro-Magnetic Interference (EMI) reduction. The average boost clock is 2 MHz and the clock is spread between 0.8 MHz and 4 MHz.

Boost Output Voltage (VHV) Control Principle

The asynchronous control starts the boost converter as soon as the VHV voltage drops below the reference set by the 4-bit DAC and stops the boost converter when the VHV voltage rises above the reference again.

Due to the slow response time of the control loop, the VHV voltage may drop below the set voltage before the control loop compensates for it. In the same manner, VHV can rise higher than the set value. This effect may reduce the maximum output voltage available. Please refer to Figure 7 below.

The asynchronous control reduces switching losses and improves the output (VHV) regulation of the DC/DC converter under light load, particularly in the situation where the TCC-202 only maintains the output voltages to fixed values.

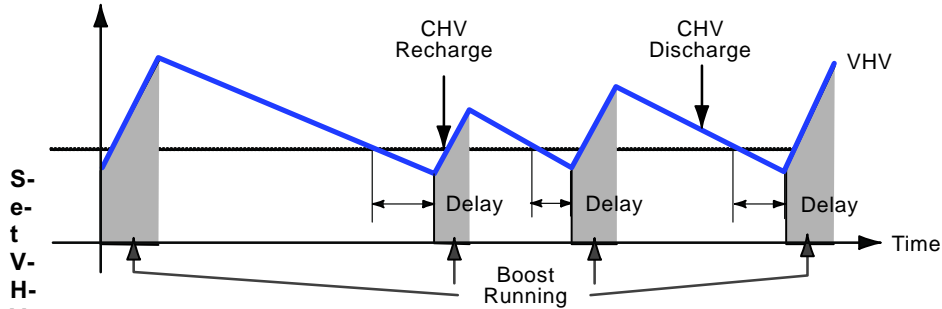

Figure 6. VHV Voltage Waveform

High Impedance (High Z) Feature

In shutdown mode the OUT pins are set to a high impedance mode (high Z). Following is the principle of operation for the control IC:

1. The DAC output voltage V_{OUT} is defined by:

$$V_{OUT} = \frac{\text{DAC code}}{255} \times 24 \text{ V} \times 2 \quad (\text{eq. 1})$$

2. The voltage VHV defines the maximum supply voltage of the DAC supply output regulator and is set by a 4-bit control.
3. The maximum DAC DC output voltage V_{OUT} is limited to $(VHV - 2 \text{ V})$.
4. The minimum output DAC voltage V_{OUT} is 1.0 V max.

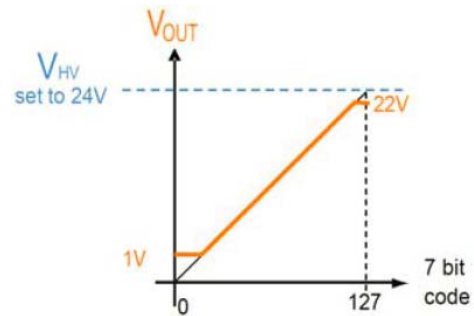

Figure 8. DAC Output Range Example B

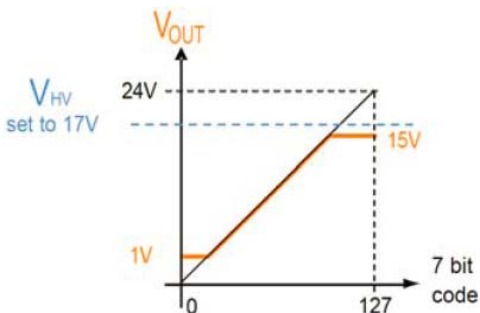

Figure 7. DAC Output Range Example A

Digital Interface

The control IC is fully controlled through a MIPI RFFE-compliant digital interface. The digital interface is described in the following sections of this document, for detailed programming instructions please refer to the programming guide, available by contacting ON Semiconductor.

Turbo-Charge Mode

The TCC-202 control IC has a Turbo-Charge mode that significantly shortens the system settling time when changing programming voltages. In Turbo-Charge mode the DAC output target voltage is temporarily set to either a delta voltage above or a delta voltage below the actual desired target for the TCDLY time. It is recommended that V_{HV} be set to 24 V when using Turbo-Charge mode.

Glide Mode

Unlike turbo mode, which is intended to reduce the charging time, the glide mode extends the transition time of each DAC output. Each DAC has an individual control for turbo mode, glide mode or regular voltage switching. The glide mode can be enabled for a particular DAC through the INDEX register, by setting DAC State to '1' when glide mode is enabled, turbo mode is off for a particular DAC, but one DAC can be gliding while the other is turbo.

During glide mode the output voltage of a DAC is either increased or decreased to its set end point, in max 255 steps, where each DAC time step can be programmed between 2 μ s to 64 μ s. For programming the glide mode refer to the application note (coming soon). A programming input is not required to maintain a glide transition, all step controls are maintained by the part. Only the inputs to define the glide need to be programmed.

RF Front-End Control Interface (MIPI RFFE Interface)

The TCC-202 is a read/write slave device which is fully compliant to the MIPI Alliance Specification for RF Front-End Control Interface (RFFE) Version 1.10.00 26 July 2011. This device is rated at full-speed operation for $1.62\text{ V} < V_{IO} < 1.98\text{ V}$.

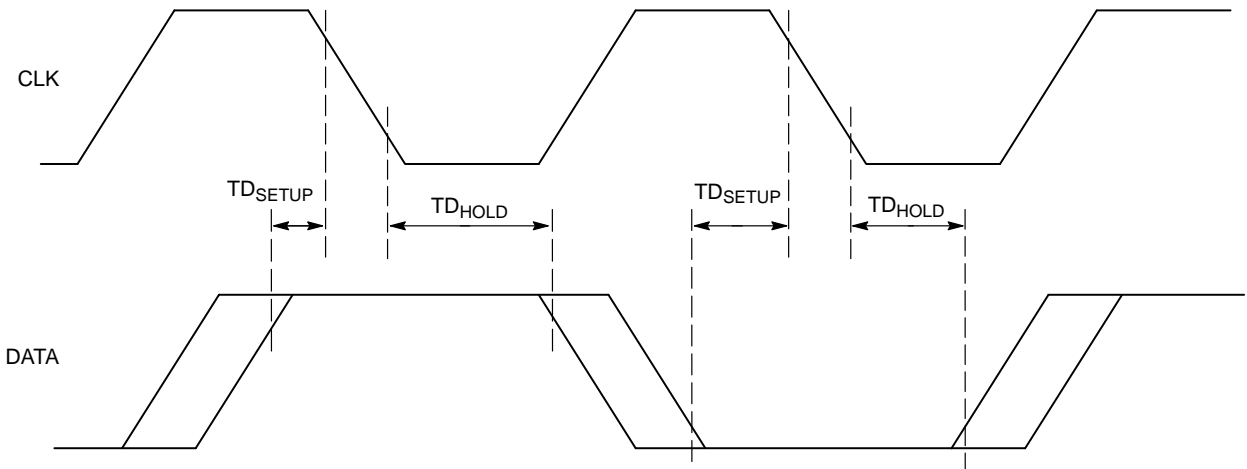

Figure 9. MIPI-RFFE Signal Timing during Master Writes to PTIC Control IC

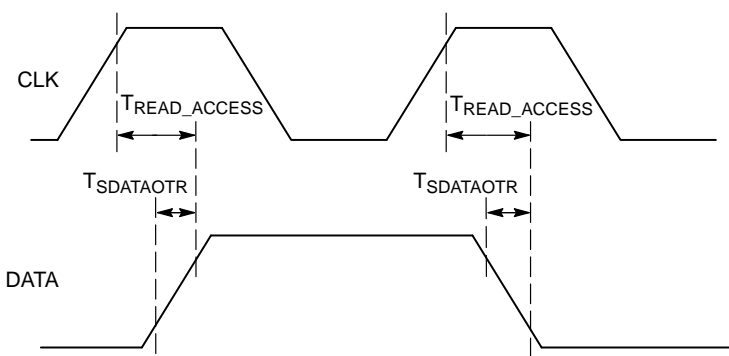

Figure 10. MIPI-RFFE Signal Timing during Master Reads from PTIC Control IC

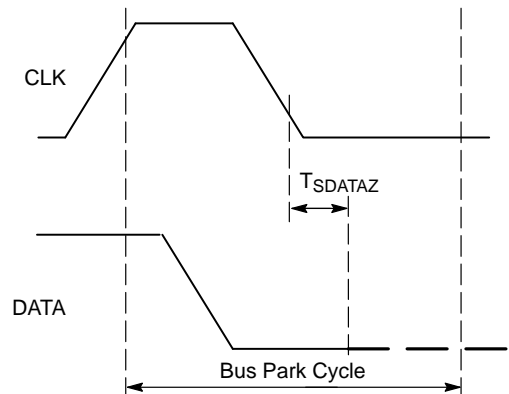

Figure 11. Bus Park Cycle Timing when MIPI-RFFE Master Reads from PTIC Control IC

TCC-202

Table 10. MIPI RFFE INTERFACE SPECIFICATION

(T_A = -30 to +85°C; 2.3 V < VDDA < 5.5 V; 1.62 < VIO < 1.98 V; unless otherwise specified)

Parameter	Description	Min	Typ	Max	Unit	Comments
F _{SCLK}	Clock Full-Speed Frequency	0.032	–	26	MHz	Full-Speed Operation: 1.62 V < VIO < 1.98 V
T _{SCLK}	Clock Full-Speed Period	0.038	–	32	μs	Full-Speed Operation: 1.62 V < VIO < 1.98 V
T _{SCLKIH}	CLK Input High Time	11.25	–	–	ns	Full-Speed
T _{SCLKIL}	CLK Input Low Time	11.25	–	–	ns	Full-Speed
TD _{SETUP}	Write DATA Setup Time	–1	–	1	ns	Full-Speed
TD _{HOLD}	Write DATA Hold Time	–5	–	5	ns	Full-Speed
T _{READ_ACCESS}	Read DATA valid from CLK rising edge	–	–	7.11	ns	Full Speed at VIO = 1.80 V, = 25°C and max 15 pF load on DATA pin
T _{READ_ACCESS}	Read DATA valid from CLK rising edge	–	–	9.11	ns	Full Speed at VIO = 1.80 V, = 25°C and max 50 pF load on DATA pin

The control IC contains thirteen 8-bit registers. Register content is described in Table 11. Some additional registers implemented as provision, are not described in this document.

Table 11. MIPI RFFE ADDRESS MAP

Register Address	Description	Purpose	Access Type	Size (bits)
0x00	DAC Configuration (Enable Mask)	High voltage output enable mask	Write	7
0x01	Turbo Register DAC A, B	Turbo-charge configuration DAC A, B (Note 2)	Write	8
0x02	DAC A Register	OUT A value [6:0]	Write	8
0x03	DAC B Register	OUT B value [6:0]	Write	8
0x09	Wake Up	Wake-Up Controls	Write	8
0x10	Boost Voltage (VHV)	Settings for the boost high voltage	Write	8
0x12	Turbo-Charge Delay DAC A, B	Turbo-charge delay steps DAC A, B	Write	8
0x13	Turbo-Charge Delay DAC A, B	Turbo-charge delay, multiplication DAC A, B	Write	8
0x1A	MIPI-RFFE STATUS	Detect MIPI protocol errors	Read/Write	8
0x1B	RFFE Group SID	MIPI RFFE group slave	Write	8
0x1C	Power Mode and Trigger Register	Power mode & trigger control	Write	8
0x1D	Product ID Register	Product number (Notes 3 and 5)	Write	8
0x1E	Manufacturer ID Register	MN (10 bits long) Manufacturer ID[7:0] (Note 4)	Write	8
0x1F	Unique Slave Identifier Register (USID)	Spare [7:6] [5,4] = Manufacturer ID [9:8]	Write	8
0x2C	Glide Timer Settings	[6:5] Turbo and Glide control / [4:0] Glide Timer setting / Need extended write for this register	Write	8

2. The details for configuration of Turbo mode should be ascertained from the Programming Guide, available from ON Semiconductor.
3. The two least significant bits from Product ID register are programmed in OTP during manufacture. The other six bits of Product ID are hardcoded in ASIC.
4. Manufacture ID is hardcoded in ASIC, and mapped in a READ-only register, not programmed in OTP.
5. TCC-202 supports WRITE access to Product ID, only in respect to comply with MIPI RFFE specification 6.8.3, Programmable USID", of MIPI Alliance Specification for RF Front-End Control Interface (RFFE) Version 1.00.00 26 July 2011.

TCC-202

Table 12. REGISTER DETAILS The following are the details of the available RFFE registers:

Register RFFE:	RFFE_REG_0x00	Address RFFE A[4:0]:	0x00
-----------------------	----------------------	-----------------------------	-------------

Reset Source: nreset_dig or SWR = '1' or PWR_MODE = '01' (transition through STARTUP mode)

	6	5	4	3	2	1	0
Bits	SS Enable	Reserved	Reserved	DAC A (Note 6)	DAC B (Note 6)	Reserved	Reserved
Reset	W-1	U-0	U-0	W-0	W-0	U-0	U-0

6. When any of the bits [3:2] are written with '0', the corresponding DAC is disabled, but the Turbo-Charge process which is already started, will not be stopped.

7. If all bits [3:2] are '0', then incoming DAC messages will be ignored, until at least one of [3:1] is set '1'.

Bit [6]: Spread Spectrum enable

0: SS disabled

1: SS enabled

Bit [3]: Control DAC A

0: off (default)

1: enabled

Bit [2]: Control DAC B

0: off (default)

1: enabled

Register RFFE:	RFFE_REG_0x01	Address RFFE A[4:0]:	0x01
-----------------------	----------------------	-----------------------------	-------------

Reset Source: nreset_dig or SWR = '1' or PWR_MODE = '01' (transition through STARTUP mode)

	7	6	5	4	3	2	1	0
Bits					Reserved			
Reset	W-0	W-0	W-0	W-0	W-0	W-0	W-0	W-0

Register RFFE:	RFFE_REG_0x02	Address RFFE A[4:0]:	0x02
-----------------------	----------------------	-----------------------------	-------------

Reset Source: nreset_dig or SWR = '1' or PWR_MODE = '01' (transition through STARTUP mode)

	7	6	5	4	3	2	1	0
Bits	Reserved	DAC A value [6:0]						
Reset	U-0	W-0	W-0	W-0	W-0	W-0	W-0	W-0

Register RFFE:	RFFE_REG_0x03	Address RFFE A[4:0]:	0x03
-----------------------	----------------------	-----------------------------	-------------

Reset Source: nreset_dig or SWR = '1' or PWR_MODE = '01' (transition through STARTUP mode)

	7	6	5	4	3	2	1	0
Bits	Not Used	DAC B value [6:0]						
Reset	W-0	W-0	W-0	W-0	W-0	W-0	W-0	W-0

TC_STP_DACx [1:0]	Turbo Steps for TCDLY [us]
00	3
01 (default)	5
10	7
11	9

Register RFFE:	RFFE_REG_0x12	Address RFFE A[4:0]:	0x12
-----------------------	----------------------	-----------------------------	-------------

Reset Source: nreset_dig or SWR = '1' or PWR_MODE = '01' (transition through STARTUP mode)

	7	6	5	4	3	2	1	0
Bits	Reserved		Reserved		TC_STP_DAC_B		TC_STP_DAC_A	
Reset	U-0	U-0	U-0	U-0	W-0	W-1	W-0	W-1

TCC-202

Register RFFE:	RFFE_REG_0x13	Address RFFE A[4:0]:	0x13
-----------------------	----------------------	-----------------------------	-------------

Reset Source: nreset_dig or SWR = '1' or PWR_MODE = '01' (transition through STARTUP mode)

	7	6	5	4	3	2	1	0
Bits	Reserved		Reserved		TCM_B		TCM_A	
Reset	U-0	U-0	U-0	U-0	W-0	W-0	W-0	W-0

TCM [1:0]	Turbo Multiplication Factor
00 (default)	4
01	3
10	2
11	1

Step [us]	DAC state	0	1	2	3	4	5	6	7	8	9	10	11
9	TCDLY	Turbo OFF		18	27	36	45	54	63	72	81	90	99
7	TCDLY	Turbo OFF		14	21	28	35	42	49	56	63	70	77
5 (default)	TCDLY	Turbo OFF		10	15	20	25	30	35	40	45	50	55
3	TCDLY	Turbo OFF		6	9	12	15	18	21	24	27	30	33

The value of Turbo time is deducted based on the hardware comparison of new DAC value in respect to old DAC value, as follows:

If DAC new > DAC old, then $T_{UP} = TCDLY$

If DAC new < DAC old, and DAC_new_divby2 < 21, then $T_{DOWN} = TCDLY + TCM * (21 - DAC_new_divby2)$ If DAC new < DAC old, and DAC_new_divby2 > 21, then $T_{DOWN} = TCDLY$

If DAC new < DAC old, and DAC_new_divby2 = 21, then $T_{DOWN} = TCDLY$

Register RFFE:	RFFE_REG_0x9	Address RFFE A[4:0]:	0x09
-----------------------	---------------------	-----------------------------	-------------

Reset Source: nreset_dig or SWR = '1' or PWR_MODE = '01' (transition through STARTUP mode)

	7	6	5	4	3	2	1	0
Bits		Reserved			DAC_WAKEUP_CTRL	Turbo Latency Select	Reserved	Reserved
Reset	U-0	U-0	U-0	U-0	W-0	W-0	W-0	W-0

Bit [3]: DAC Wake-up Control applicable to Wake-up from LP

0 : (default) Don't apply Turbo when Wake-up from LP STD or LP FTA

1: Always apply Turbo UP when Wake-up from LP STD or LP FTA. Turbo UP is calculated based on DAC value prior to enter LP STD or LP FTA mode.

NOTE 1: Turbo is NOT applied after Wake-up to the DACs which are programmed with 0x00 in the DAC value register

NOTE 2: Turbo is NOT applied after Wake-up from FTA mode if a trigger (Turbo, Normal, Glide) was generated while TC2x2 was in LP FTA mode

NOTE 3: When Bit[3] = '1', then Turbo is applied after Wake-up regardless if:

- DAC values are updated or not
- last DAC value update is equal with old DAC value

NOTE 4: When RFFE_REG_0x31 / Wake-up DAC Ctrl is '0' (default) Turbo after Wake-Up is applied after first vlv_too_lowfalling edge is detected. When RFFE_REG_0x31 / Wake-up DAC Ctrl is '1' Turbo after Wake-up is applied after rc_clk starts.

Bit [2]: Turbo UP latency Select when Wake-up from LP.

This field has no effect when DAC_WAKEUP_CTRL[1:0] = '00'

0: (default) Turbo UP latency is 50 μ s

1: Turbo UP latency is 100 μ s

TCC-202

Register RFFE:	RFFE_REG_0x10	Address RFFE A[4:0]:	0x10					
Reset Source: nreset_dig or SWR = '1' or PWR_MODE = '01' (transition through STARTUP mode)								
	7	6	5	4	3	2	1	0
Bits	Reserved			Fixed	Boost voltage value			
Reset	U-0	U-0	U-0	U-1	W-1	W-0	W-1	W-1

Bit [3:0]: Boost voltage value

Register RFFE:	RFFE_STATUS_0x1A	Address RFFE A[4:0]:	0x1A					
Reset Source: nreset_dig or SWR = '1' or PWR_MODE = '01' (transition through STARTUP mode)								
	7	6	5	4	3	2	1	0
Bits	SWR	CFPE	CLE	AFPE	DFPE	RURE	WURE	BGE
Reset	W-0	R-0	R-0	R-0	R-0	R-0	R-0	R-0

RFFE_STATUS register can be read any time after power-up without the need to enable the Read Operation as described below.

SWR Soft-Reset MIPI-RFFE registers

Write '1' to this bit to reset all the MIPI-RFFE registers, except RFFE_REG_0x1C, RFFE_USID, and RFFE_GROUP_SID. This bit will always Read-back '0'.

The soft reset occurs in the last clock cycle of the MIPI-RFFE frame which Writes '1' to this bit.

Right immediately after this frame, all the MIPI-RFFE registers have the reset value and are ready to be reprogrammed as desired.

The OTP duplicated registers are reset to the values written in OTP.

SWR can be written only by USID messages. GSID and Broadcast frames will be ignored when writing to this register field. RFFE_STATUS Bits [6:0] are set '1' by hardware to flag when a certain condition is detected, as described below. RFFE_STATUS Bits [6:0] cannot be written, but it is cleared to '0' under following conditions:

- Hardware Self-reset is applied after RFFE_STATUS is READ
- When SWR is written '1' with USID frames
- When power mode transitions through STARTUP mode '01'
- After Power-up Reset

CFPE

1: Command frame with parity error received.

On the occurrence of this error, the slave will ignore the entire Command Sequence

CLE

1: Incompatible command length, due to unexpected SSC received before command length to be completed.

On the occurrence of this error, the slave will accept Write data up to the last correct and complete frame. When MIPI-RFFE multi-byte Read command is detected, the slave will always replay with an extended Read command of length of one byte.

AFPE

1: Address frame with parity error received.

On the occurrence of this error, the slave will ignore the entire Command Sequence

DFPE

1: Data frame with parity error received.

On the occurrence of this error, the slave will ignore only the erroneous data byte (s)

RURE

1: Read of non-existent register was detected.

On the occurrence of this error, the slave will not respond to the Read command frame.

When the Read Operation is not enabled, any read from an address other than 0x1A, will set RURE and the slave will not respond to the Read command frame.

When the Read Operation is enabled, any read from an unoccupied RFFE register address will set RURE.

WURE

1: Write to non-existent register was detected.

On the occurrence of this error, the slave discards data being written, and on the next received frame, proceeds as normal

BGE

1: Read using the Broadcast ID was detected

On the occurrence of this error, the slave will ignore the entire Command Sequence

TCC-202

Register RFFE:	RFFE_GROUP_SID_0x1B	Address RFFE A[4:0]:	0x1B
-----------------------	----------------------------	-----------------------------	-------------

Reset Source: nreset_dig or PWR_MODE = '01' (transition through STARTUP mode)

	7	6	5	4	3	2	1	0
Bits	Reserved	Reserved	Reserved	Reserved	GSID[3]	GSID[2]	GSID[1]	GSID[0]
Reset	0	0	0	0	W-0	W-0	W-0	W-0

GSID = Group Slave Identifier Register

NOTE: The GSID[3:0] field can be written directly by messages using USID.

NOTE: GSID value is NOT retained during SHUTDOWN power mode.

NOTE: GSID value is not affected by SWR bit from RFFE_STATUS register

NOTE: Frames using USID = GSID, can write only to RFFE_REG_0x1C[7:6] and [2:0].

NOTE: RFFE READ frames containing GSID will be ignored

Register RFFE:	RFFE_REG_0x1C	Address RFFE A[4:0]:	0x1C
-----------------------	----------------------	-----------------------------	-------------

Reset Source: nreset_dig or PWR_MODE = '01' (transition through STARTUP mode)

	7	6	5	4	3	2	1	0
Bits	Power Mode (Note 12)		Trigger Mask 2 (Notes 8, 9, 10, 11)	Trigger Mask 1 (Notes 8, 9, 10, 11)	Trigger Mask 0 (Notes 8, 9, 10, 11)	Trigger 2	Trigger 1	Trigger 0
Reset	W-0	W-0	W-0	W-0	W-0	W-0	W-0	W-0

8. Trigger Mask bits [5:3] can be changed, either set or cleared, only with an individual message using USID

9. During broadcast MIPI-RFFE accesses using GSID = '0000', Trigger bits [2:0] are masked by the pre-existent setting of Trigger Mask Bits [5:3]

10. During Individual MIPI-RFFE accesses using USID, Trigger bits [2:0] are masked by the incoming Trigger Mask bits [5:3] within the same write message to RFFE_REG_0x1C register. During Individual MIPI-RFFE accesses using USID, pre-existent setting of Trigger Mask Bits [5:3] is ignored.

11. When RFFE_REG_0x1C/ Trigger_Mask_2 = '1' and Trigger_Mask_1 = '1' and Trigger_Mask_0 = '1', then DAC messages will be sent to DACs immediately after RFFE_REG_0x04 is received, without waiting for any trigger

12. Power mode field bits [7:6] and Triggers bits [2:0] can be changed by either MIPI-RFFE broadcast messages when USID field within the Register Write Command is 0x0, or individual messages when USID fields within the Register Write Command is equal with RFFE_REG_0x1F[3:0]

NOTE: All the 8 bits of RFFE_REG_0x1C register bits are NOT affected by SWR bit from RFFE_STATUS register

Bit [7:6]: Power Mode

00: ACTIVE mode, defined by following hardware behavior:

- Boost Control active, VHV set by Digital Interface
- Vout A and B enabled and controlled by Digital Interface

01: STARTUP mode, defined by following hardware behavior: o

- Boost Control active, VHV set by Digital Interface
- Vout A and B disabled

10: LOW POWER mode is defined by following hardware behavior:

- Digital interface is active, while all other circuits are in lowpower mode

11: Reserved (State of hardware does not change)

Bit 5: Mask trigger 2

0: Trigger 2 not masked. Data goes to destination register after bit 2 is written value 1 (default)

1: Trigger 2 is masked. Data goes directly to the destination register

Bit 4: Mask trigger 1

0: Trigger 1 not masked. Data goes to destination register after bit 1 is written value 1 (default)

1: Trigger 1 is masked. Data goes directly to the destination register.

Bit 3: Mask trigger 0

0: Trigger 0 not masked. Data goes to destination register after bit 0 is written value 1 (default)

1: Trigger 0 is masked. Data goes directly to the destination register.

Bit 2: Trigger 2

Write 1 to this bit, to move data from shadowregisters into destination register. This trigger can be masked by bit 5.

Bit 1: Trigger 1

Write 1 to this bit, to move data from shadowregisters into destination register. This trigger can be masked by bit 4.

Bit 0: Trigger 0

Write 1 to this bit, to move data from shadowregisters into destination register. This trigger can be masked by bit 3.

TCC-202

Register RFFE:	RFFE_PRODUCT_ID_0x1D	Address RFFE A[4:0]:	0x1D
-----------------------	-----------------------------	-----------------------------	-------------

Reset Source: N/A

	7	6	5	4	3	2	1	0
Bits	PID7	PID6	PID5	PID4	PID3	PID2	PID1	PID0 (1)
Reset	0	0	1	0	0	0	0	OTP[4]

Bits [7:1] are hardcoded in ASIC

Bits [0] can be programmed in OTP during manufacturing

Register RFFE:	RFFE_MANUFACTURER_ID_0x1E	Address RFFE A[4:0]:	0x1E
-----------------------	----------------------------------	-----------------------------	-------------

Reset Source: N/A

	7	6	5	4	3	2	1	0
Bits	MPN7	MPN6	MPN5	MPN4	MPN3	MPN2	MPN1	MPN0
Reset	0	0	1	0	1	1	1	0

Register RFFE:	RFFE_USID_0x1F	Address RFFE A[4:0]:	0x1F
-----------------------	-----------------------	-----------------------------	-------------

Reset Source: nreset_dig or PWR_MODE = '01' (transition through STARTUP mode)

	7	6	5	4	3	2	1	0
Bits	Reserved (2)		MPN9 (2)	MPN8 (2)	USID3 (1)	USID2 (1)	USID1 (1)	USID0 (1)
Reset	0	0	0	1	W-0	W-1	W-1	W-1

USID = Unique Slave Identifier Register

1. USID field can be changed by:

- MIPI-RFFE broadcast messages when USID field within the Register Write Command is 0b0000
- MIPI-RFFE individual messages when USID field within the Register Write Command equal with content of RFFE_REG_0x1F[3:0]

2. In the sequence of writing USID field, the upper [7:4] must match the value 0b0001 hardcoded in the RFFE register 0x1F

NOTE: USID value is NOT retained during SHUTDOWN power mode.

NOTE: USID value is not affected by SWR bit from RFFE_STATUS register.

TCC-202

Register 0 Write Command Sequence

The Command Sequence starts with an SSC which is followed by the Register 0 Write Command Frame. This Frame contains the Slave address, a logic one, and the seven bit word that will be written to Register 0. The Command Sequence is depicted below.

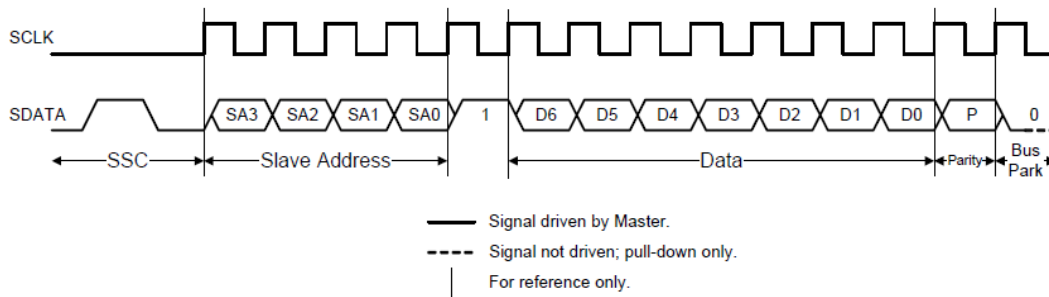

Figure 12. Register 0 Write Command Sequence

Table 13. RFFE COMMAND FRAME FOR REGISTER 0 WRITE COMMAND SEQUENCE

Description	SSC		Command Frame																
DAC Configuration	1	0	SA (3,0)							1	0	0	0	0	0	0	0	P	BP

Register Write Command Sequence

The Write Register command sequence may be used to access each register (addresses 0–31).

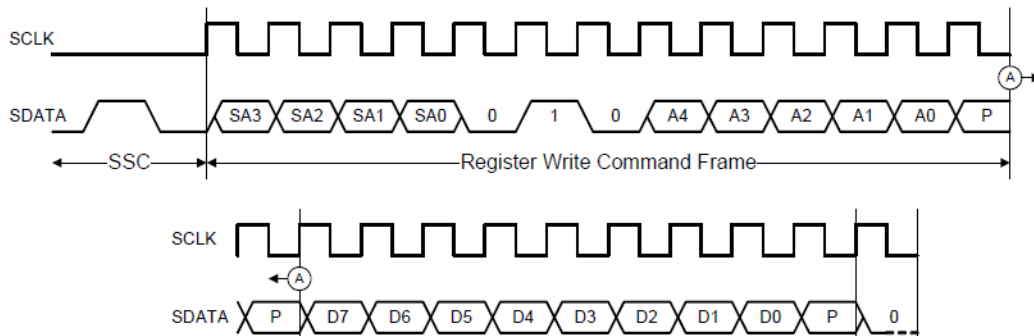

Figure 13. Register Write Command Sequence

Table 14. RFFE COMMAND FRAME FOR REGISTER WRITE COMMAND SEQUENCE for DACs Loading Procedure

Description	SSC		Command Frame											Data Frame		BP		
Turbo Charge Settings	1	0	SA (3,0)	0	1	0	0	0	0	0	0	0	1	P	Turbo charge (7:0)		P	BP
Register Write DAC A	1	0	SA (3,0)	0	1	0	0	0	0	0	1	0	P	DAC_A (6:0)		P	BP	
Register Write DAC B	1	0	SA (3:0)	0	1	0	0	0	0	0	1	1	P	DAC_B (6:0)		P	BP	

This sequence can be used for Read/Write procedure for some other purposes as shown on the following table:

Table 15. OTHER RFFE COMMAND SEQUENCES

Description	SSC		Command Frame										Data Frame							
Active Mode	1	0	SA (3,0)	0	1	0	1	1	1	0	0	P	0	0	X	X	X	X	X	BP
Startup Mode	1	0	SA (3,0)	0	1	0	1	1	1	0	0	P	0	1	X	X	X	X	X	BP
Low Power	1	0	SA (3:0)	0	1	0	1	1	1	0	0	P	1	0	X	X	X	X	X	BP
Reserved	1	0	SA (3,0)	0	1	0	1	1	1	0	0	P	1	1	X	X	X	X	X	BP
Product ID	1	0	SA (3,0)	0	1	0	1	1	1	0	1	P	0	0	1	0	0	0	0/1	BP
Manufacturer ID	1	0	SA (3:0)	0	1	0	1	1	1	1	0	P	0	0	1	0	1	1	0	BP
Manufacturer USID	1	0	SA (3,0)	0	1	0	1	1	1	1	1	P	0	0	0	1	USID			BP

Extended Register Write Command Sequence

In order to access more than one register in one sequence this message could be used. Most commonly it will be used for loading three DAC registers at the same time. The four LSBs of the Extended Register Write Command Frame determine the number of bytes that will be written by the Command Sequence. A value of 0b0000 would write one byte and a value of 0b1111 would write sixteen bytes.

If more than one byte is to be written, the register address in the Command Sequence contains the address of the first extended register that will be written to and the Slave’s local extended register address shall be automatically incremented by one for each byte written up to address 0x1F, starting from the address indicated in the Address Frame.

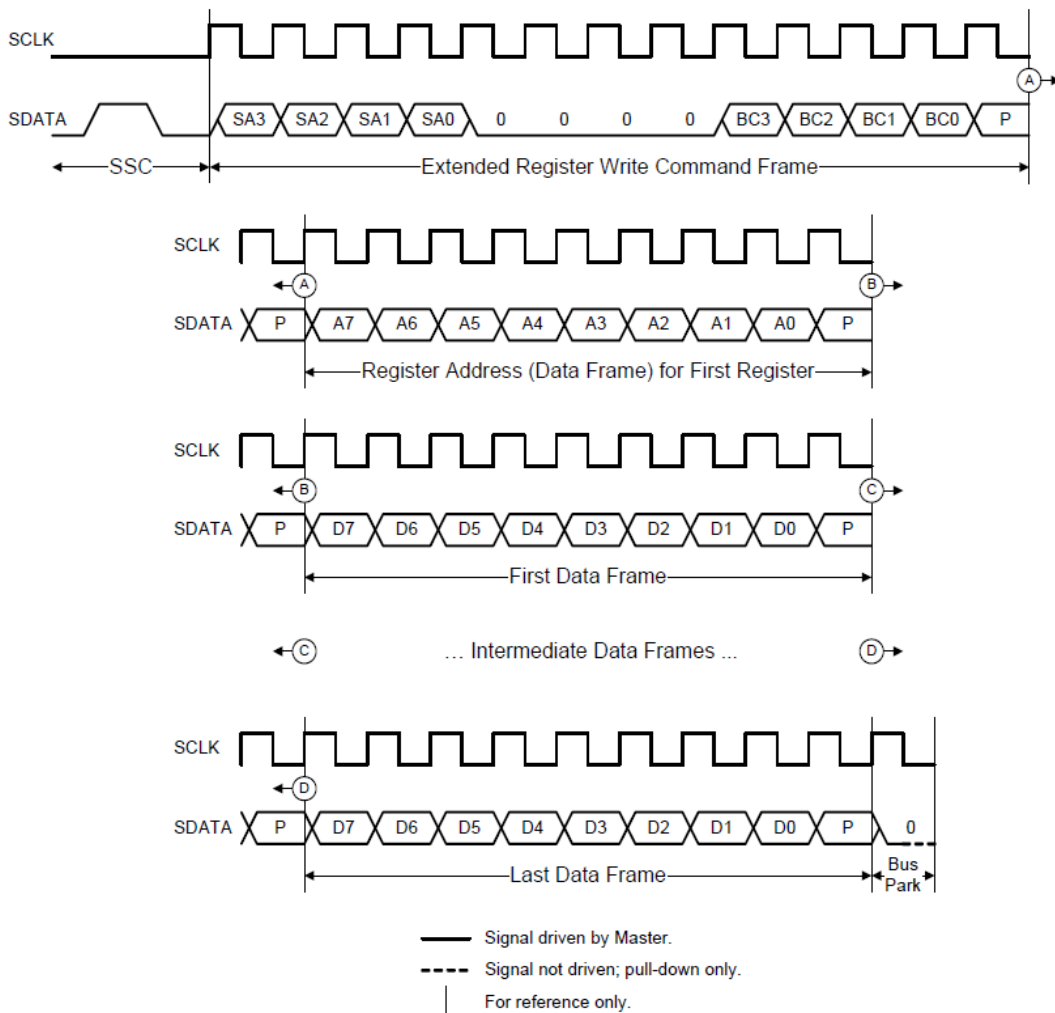

Figure 14. Extended Register Write Command Sequence

TCC-202

Table 16. RFFE COMMAND FRAME for Extended Register Write Command Sequence for DACs Loading Procedure

Description	SSC		Command Frame																				
																	<byte count>						
Extended Register Writtee DAC A&BB&&CC	1	0	SA (3,0)	0	0	0	0	0	0	0	0	0	0	0	1	0	P						
Data Frame																							
<starting address>																							
0	0	0	0	0	0	0	0	1	P	TC(7:0)				P	DAC A (6:0)			P	DAC_B (6:0)			P	BP

Register Read Command Sequence

MIPI-RFFE Read operation can access RFFE_STATUS register from TCC-202 device address 0x1A. Extended Register Read command sequence is not supported.

Configuration Settings

Table 17. DAC CONFIGURATION (ENABLE MASK) at [0x00] Defaults shown as (x)

Bit 6 (1)	Bit 5 (0)	Bit 4 (0)	Bit 3 (0)	Bit 2 (0)	Bit 1 (0)	Bit 0 (0)
SSE	reserved	reserved	DAC A	DAC B	reserved	reserved

SSE = 0 spread spectrum disabled, SSE = 1 spread spectrum enabled (default), this controls the average boost clock which is nominally 2 MHz and spread between 0.8 MHz and 3.2 MHz when enabled (default).

Table 18. DAC MODE SETUP: DAC ENABLE

Bit3	Bit2	DAC A	DAC B	
0	0	Off	Off	(Default)
0	1	Off	Enabled	
1	0	Enabled	Off	
1	1	Enabled	Enabled	

Table 19. BOOST DAC MODE SETUP (VHV) at [0x10] (Notes 13, 14)

Bit 7*	Bit 6*	Bit 5*	Bit 4	Bit 3	Bit 2	Bit 1	Bit 0	VHV (V)
0	0	0	1	0	0	0	0	13
0	0	0	1	0	0	0	1	14
0	0	0	1	0	0	1	0	15
0	0	0	1	0	0	1	1	16
0	0	0	1	0	1	0	0	17
0	0	0	1	0	1	0	1	18
0	0	0	1	0	1	1	0	19
0	0	0	1	0	1	1	1	20
0	0	0	1	1	0	0	0	21
0	0	0	1	1	0	0	1	22
0	0	0	1	1	0	1	0	23
0	0	0	1	1	0	1	1	24 (Default)
0	0	0	1	1	1	0	0	25
0	0	0	1	1	1	0	1	26
0	0	0	1	1	1	1	0	27
0	0	0	1	1	1	1	1	28

13. Bit 4 is fixed at logic 1 for reverse software compatibility

14. VHV is recommended to be set at VDac Max + 2V for non-turbo operation and + 4V when turbo is used.

* Indicates reserved bits

TCC-202

Following picture shows TCC-202 and all the necessary external components

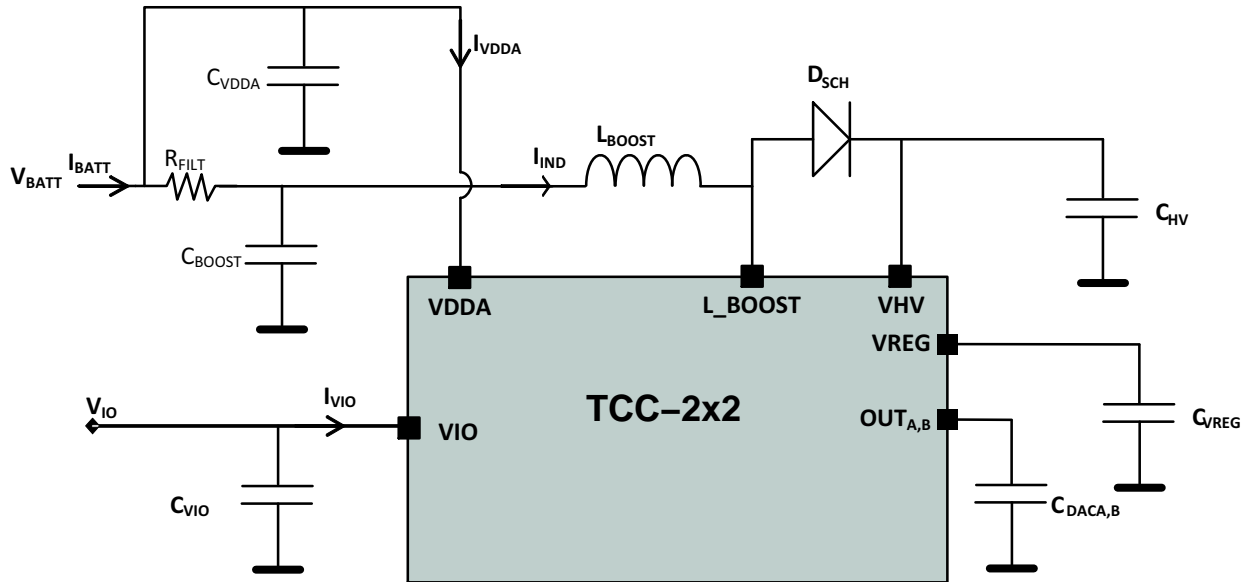

Figure 16. TCC-202 with External Components

Table 23. RECOMMENDED EXTERNAL BOM

Component	Function	Min	Typ	Max	Unit	Package
C _{VDDA}	Analog supply decoupling capacitor		1		μF	0402
C _{VIO}	VIO supply decoupling capacitor		100		nF	0201
C _{BOOST}	Boost supply capacitor		1		μF	0402
C _{HV}	Storage/filtering capacitor for the high voltage		47		nF	0402
R _{FILT}	Decoupling/filtering resistor for the Vbatt note*		3.3		Ω	0603
L _{BOOST}	Boost inductor (Note 15)		15		μH	0603
C _{VREG}	Regulator decoupling cap		220		nF	0201
C _{DACA,B}	RF decoupling cap (Note 16)*		100		pF	0201
D _{SCH}	Rectifying Schottky diode (Note 17)					SOD-923/ SOD-323

*Should be 50 V compliant.

15. The following inductor should be used: TDK VLS2010ET-150M or equivalent

16. Recommended in noise reduction only– not essential but place next to PTIC if used

17. The NSR0240P2T5G diode from ON Semiconductor and the Sunlord SPH201610H150MT are recommended. The NSR0340HT1G and NSR0340P2T5G devices may also be used.

Table 24. ORDERING INFORMATION

Device	Package	Shipping†
TCC-202A-RT	RDL (Pb-Free)	3000 / Tape & Reel

†For information on tape and reel specifications, including part orientation and tape sizes, please refer to our Tape and Reel Packaging Specifications Brochure, BRD8011/D.

TAPE & REEL DIMENSIONS

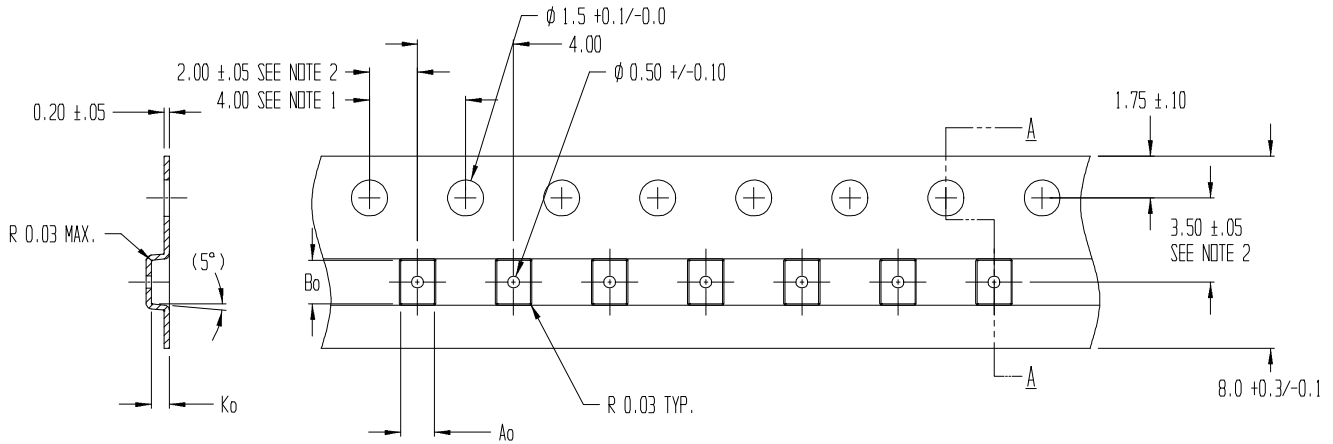

SECTION A - A

$A_0 = 1.41 \pm 0.05$
 $B_0 = 1.82 \pm 0.05$
 $K_0 = 0.75 \pm 0.05$

NOTES:

1. TO SPROCKET HOLE PITCH CUMULATIVE TOLERANCE ± 0.2
2. POCKET POSITION RELATIVE TO SPROCKET HOLE MEASURED AS TRUE POSITION OF POCKET, NOT POCKET HOLE
3. A_0 AND B_0 ARE CALCULATED ON A PLANE AT A DISTANCE "R" ABOVE THE BOTTOM OF THE POCKET.

Figure 17. WLCSP Carrier Tape Drawings

Pin 1 orientation (bump side down)

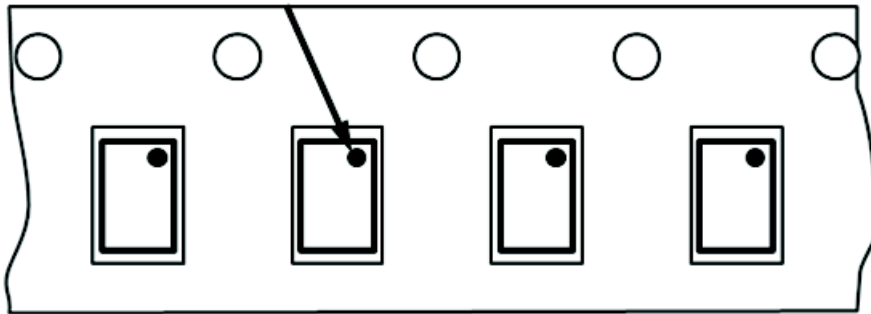

Figure 18. Orientation in Tape

ASSEMBLY INSTRUCTIONS

Note: It is recommended that under normal circumstances, this device and associated components should be located in a shielded enclosure.

TCC-202

PACKAGE DIMENSIONS

WLCSP12, 1.28x1.684
CASE 567KZ
ISSUE A

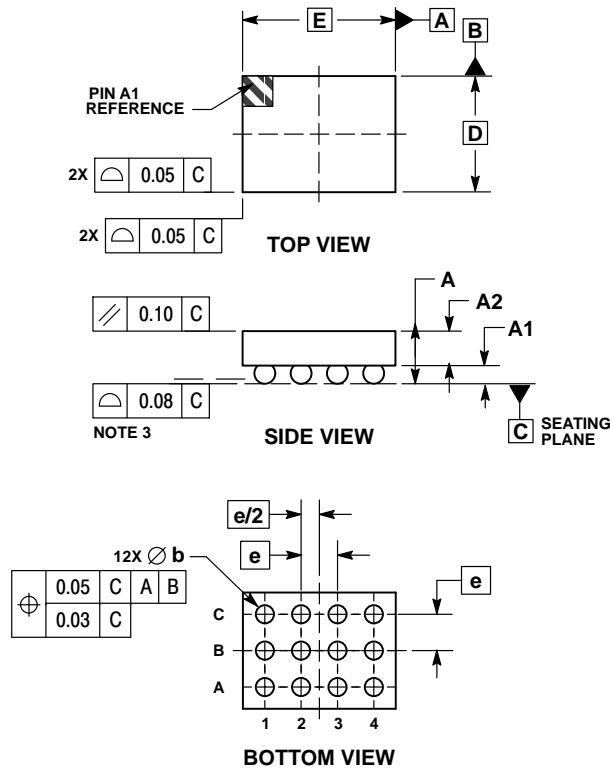

NOTES:

1. DIMENSIONING AND TOLERANCING PER ASME Y14.5M, 1994.
2. CONTROLLING DIMENSION: MILLIMETERS.
3. COPLANARITY APPLIES TO THE SPHERICAL CROWNS OF THE SOLDER BALLS.

DIM	MILLIMETERS	
	MIN	MAX
A	—	0.65
A1	0.17	0.23
A2	0.38 REF	
b	0.23	0.29
D	1.28 BSC	
E	1.684 BSC	
e	0.40 BSC	

RECOMMENDED SOLDERING FOOTPRINT*

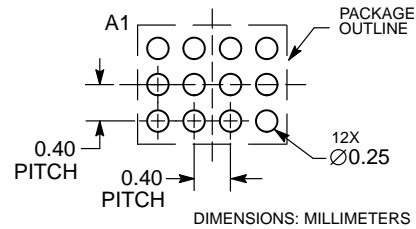

*For additional information on our Pb-Free strategy and soldering details, please download the ON Semiconductor Soldering and Mounting Techniques Reference Manual, SOLDERRM/D.

ON Semiconductor and the are registered trademarks of Semiconductor Components Industries, LLC (SCILLC) or its subsidiaries in the United States and/or other countries. SCILLC owns the rights to a number of patents, trademarks, copyrights, trade secrets, and other intellectual property. A listing of SCILLC's product/patent coverage may be accessed at www.onsemi.com/site/pdf/Patent-Marking.pdf. SCILLC reserves the right to make changes without further notice to any products herein. SCILLC makes no warranty, representation or guarantee regarding the suitability of its products for any particular purpose, nor does SCILLC assume any liability arising out of the application or use of any product or circuit, and specifically disclaims any and all liability, including without limitation special, consequential or incidental damages. "Typical" parameters which may be provided in SCILLC data sheets and/or specifications can and do vary in different applications and actual performance may vary over time. All operating parameters, including "Typicals" must be validated for each customer application by customer's technical experts. SCILLC does not convey any license under its patent rights nor the rights of others. SCILLC products are not designed, intended, or authorized for use as components in systems intended for surgical implant into the body, or other applications intended to support or sustain life, or for any other application in which the failure of the SCILLC product could create a situation where personal injury or death may occur. Should Buyer purchase or use SCILLC products for any such unintended or unauthorized application, Buyer shall indemnify and hold SCILLC and its officers, employees, subsidiaries, affiliates, and distributors harmless against all claims, costs, damages, and expenses, and reasonable attorney fees arising out of, directly or indirectly, any claim of personal injury or death associated with such unintended or unauthorized use, even if such claim alleges that SCILLC was negligent regarding the design or manufacture of the part. SCILLC is an Equal Opportunity/Affirmative Action Employer. This literature is subject to all applicable copyright laws and is not for resale in any manner.

PUBLICATION ORDERING INFORMATION

LITERATURE FULFILLMENT:

Literature Distribution Center for ON Semiconductor
19521 E. 32nd Pkwy, Aurora, Colorado 80011 USA
Phone: 303-675-2175 or 800-344-3860 Toll Free USA/Canada
Fax: 303-675-2176 or 800-344-3867 Toll Free USA/Canada
Email: orderlit@onsemi.com

N. American Technical Support: 800-282-9855 Toll Free
USA/Canada
Europe, Middle East and Africa Technical Support:
Phone: 421 33 790 2910
Japan Customer Focus Center
Phone: 81-3-5817-1050

ON Semiconductor Website: www.onsemi.com

Order Literature: <http://www.onsemi.com/orderlit>

For additional information, please contact your local Sales Representative