

# RFFM6907

2.8V to 4.0V, 915MHz Transmit/Receive Module

RFFM6907 is a front end module (FEM) intended for 868MHz to 930MHz AMI/AMR systems. This module provides separate ports for Rx and Tx paths. The Tx section provides a single stage PA with minimum output power of 30dBm and gain of 14.5dB. The Rx is a pass through. Both are combined to diversity antenna port with a DP2T switch. The device is provided in a 5.5mm x 5.0mm, 28-pin package.



Package: LGA, 28-pin,  
5.5mm x 5.0mm x 1.175mm

## Features

- Tx Output Power: 30dBm
- Tx Gain: 14.5dB
- Rx Insertion Loss: 0.6dB
- Antenna Diversity Switch
- Module Transmit Efficiency 50%

## Applications

- Wireless Automated Metering
- Wireless Alarm Systems
- Portable Battery Powered Equipment
- Smart Energy

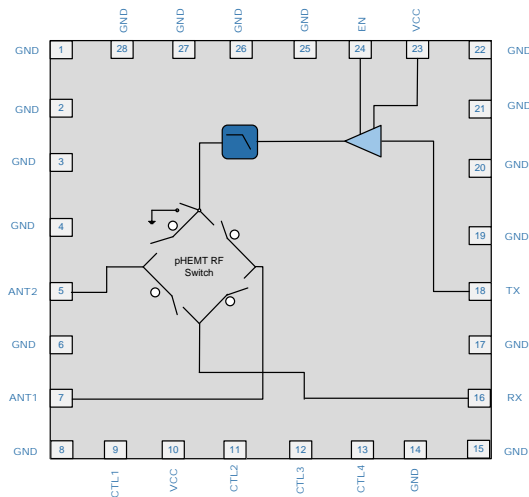

Functional Block Diagram

## Ordering Information

RFFM6907SB	Standard 5-piece bag
RFFM6907SQ	Standard 25-piece bag
RFFM6907SR	Standard 100-pieces reel
RFFM6907TR13	Standard 2500-pieces reel
RFFM6907PCK-410	Fully assembled eval board w/5-piece sample bag

## Absolute Maximum Ratings

Parameter	Rating	Unit
Voltage	5.25	VDC
Storage Temperature Range	-40 to +85	°C
Operating Temperature Range	-30 to +70	°C
Maximum Input Power to PA Pin 18 (No Damage)	32	dBm
Maximum Input Power to Pin 16 (No Damage)	35	dBm
Maximum Input Power to Pins 5 and 7 (No Damage)	35	dBm



**Caution!** ESD sensitive device.



RFMD Green: RoHS status based on EU Directive 2011/65/EU (at time of this document revision), halogen free per IEC 61249-2-21, < 1000ppm each of antimony trioxide in polymeric materials and red phosphorus as a flame retardant, and <2% antimony in solder.

Exceeding any one or a combination of the Absolute Maximum Rating conditions may cause permanent damage to the device. Extended application of Absolute Maximum Rating conditions to the device may reduce device reliability. Specified typical performance or functional operation of the device under Absolute Maximum Rating conditions is not implied.

## Nominal Operating Parameters

Parameter	Specification			Unit	Condition
	Min	Typ	Max		
<b>Overall</b>					
Frequency	868		928	MHz	
RF Port Impedance		50		Ω	
ESD, HBM	1000			V	Pin to Ground
ESD, CDM	1000			V	
Leakage Current		0.5		μA	V <sub>CC</sub> = 4V, temperature = 25°C
<b>TX Section</b>					<b>V<sub>CC</sub> = 3.6V, ENABLE = high, temperature = 25°C</b> <b>Select ANT1(CTRL2=high, CTRL1/3/4=low)</b> <b>or ANT2(CTRL1=high, CTRL2/3/4=low)</b>
Power Supply Operating Voltage	2.8	3.6	4.0	V	PA V <sub>CC</sub>
Input Power	14		16	dBm	Pin #18
CW Output Power – OP3dB	30		32	dBm	Across all rated temperatures
Operating Current		550	700	mA	P <sub>O</sub> = +30dBm
Quiescent Current		50		mA	RF=Off
Large Signal Gain	12.0	14.5		dB	P <sub>O</sub> = +30dBm, across all rated temperatures
Module PAE		50		%	Across all rated temperatures (takes into account filter and switches)
Thermal Resistance	132			°C/W	
2nd Harmonic			-20	dBc	P <sub>O</sub> = +30dBm, across all rated temperatures
3 <sup>rd</sup> to 10 <sup>th</sup> Harmonic			-72	dBc	
<b>RX Section</b>					<b>V<sub>CC</sub> = 3.6V, ENABLE = low, temperature = 25°C</b> <b>Select ANT1(CTRL4=high, CTRL1/2/3=low)</b> <b>or ANT2(CTRL3=high, CTRL1/2/4=low)</b>
Power Supply Operating Voltage	2.8	3.6	4.0	V	
V <sub>CC</sub> Operating Current		200		μA	
Insertion Loss ANT1/2 - RX		-0.6		dB	ANT1/2 - RX
Input P1dB		30		dBm	
Input Return Loss			-10	dB	Input port at ANT1/2
Output Return Loss			-10	dB	Output port at RX

Parameter	Specification			Unit	Condition
	Min	Typ	Max		
<b>Antenna Switch Section</b>					
Antenna Isolation			25	dB	ANT1 to ANT2 (TX or RX mode)
Switch Isolation			30	dB	ANT1/2 - RX
Select Control Logic = HIGH	$V_{CC} - 0.2$		$V_{CC}$	V	All five (5) logic I/Os
Select Control Logic = LOW	0		0.2	V	
Select Control Logic High Current		40	120	$\mu A$	
Select Control Logic Low Current		0.4		$\mu A$	
All five (5) logic I/Os (sink current)					

### Module Control Logic Table

Operating Mode	CTRL1	CTRL2	CTRL3	CTRL4	Enable
TX-ANT1	0	1	0	0	1
TX-ANT2	1	0	0	0	1
RX-ANT1	0	0	0	1	0
RX-ANT2	0	0	1	0	0
Shutdown	0	0	0	0	0

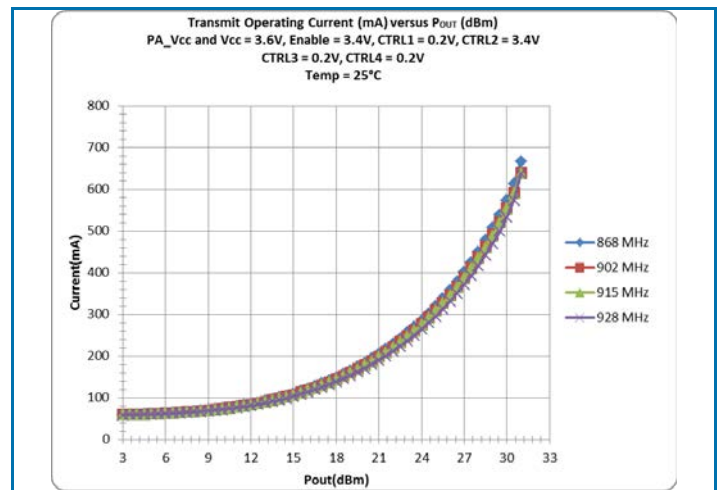
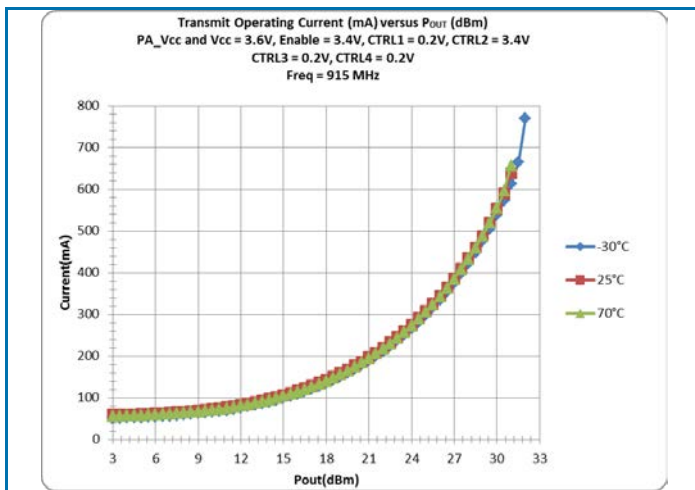
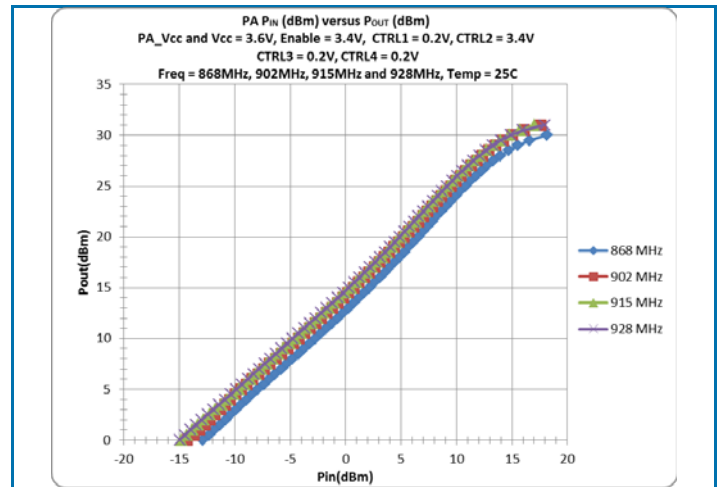
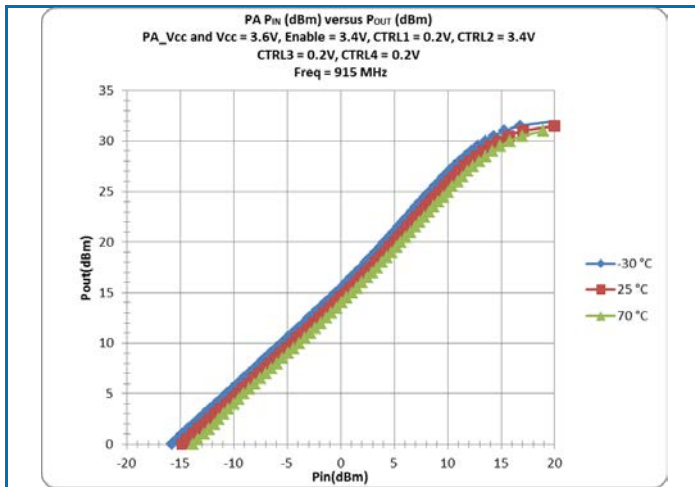
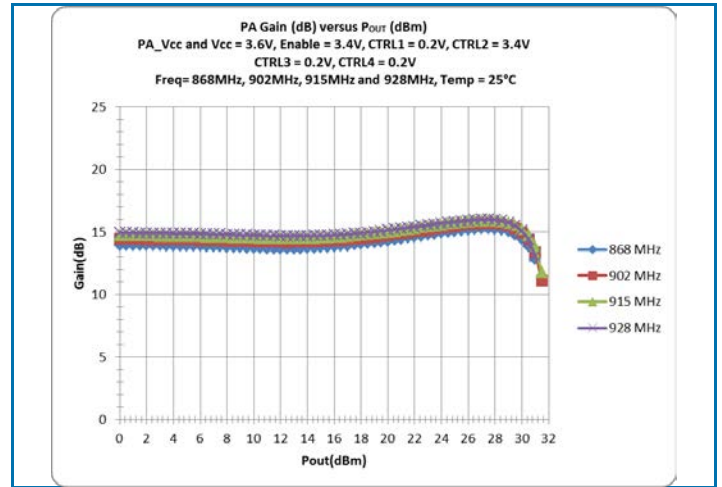
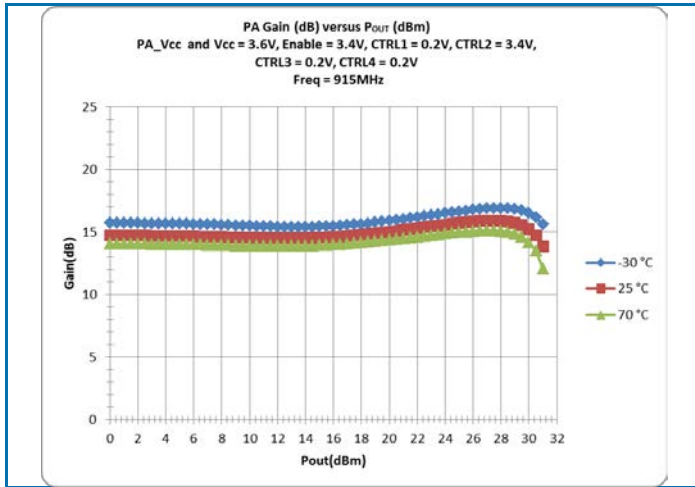

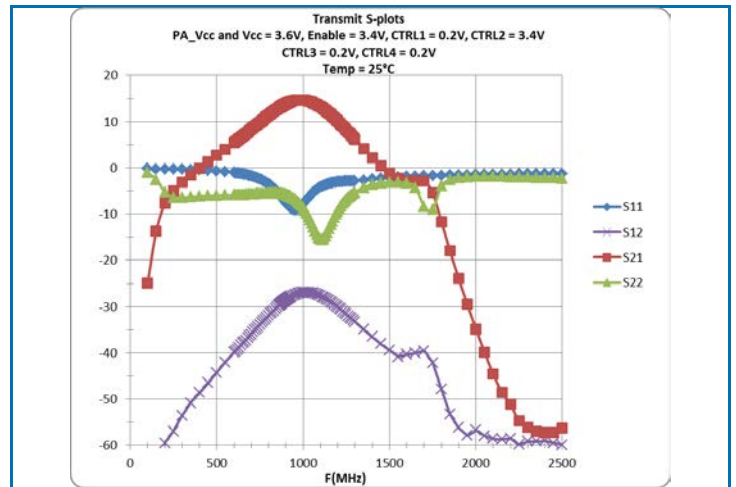
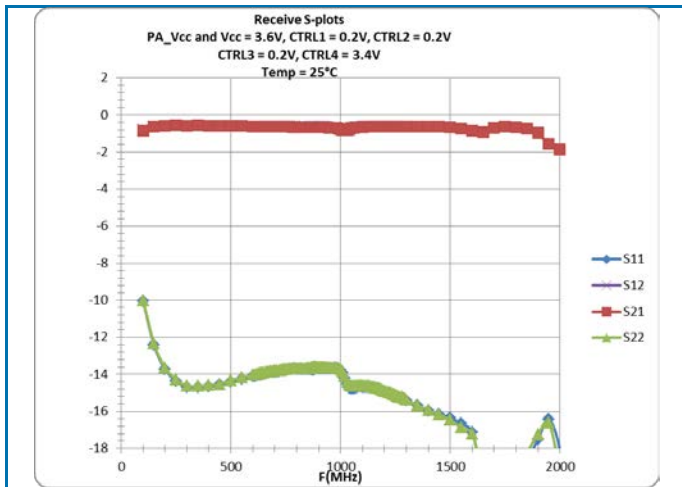
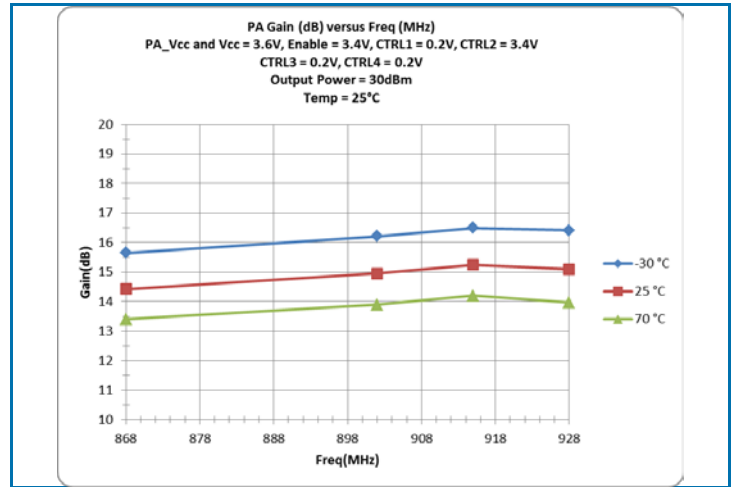
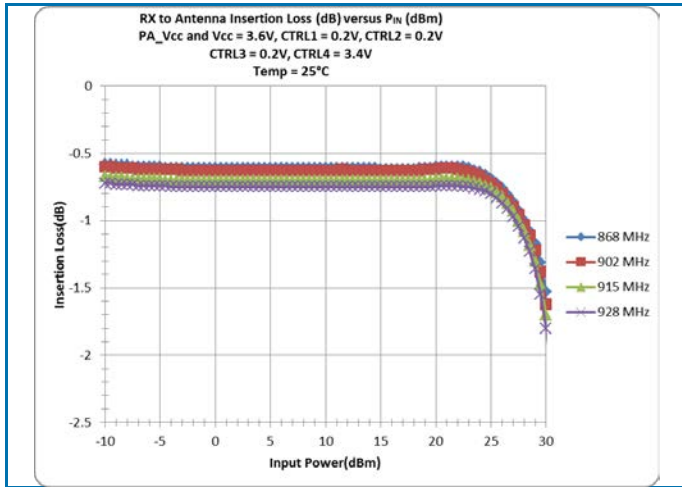

Application Schematic

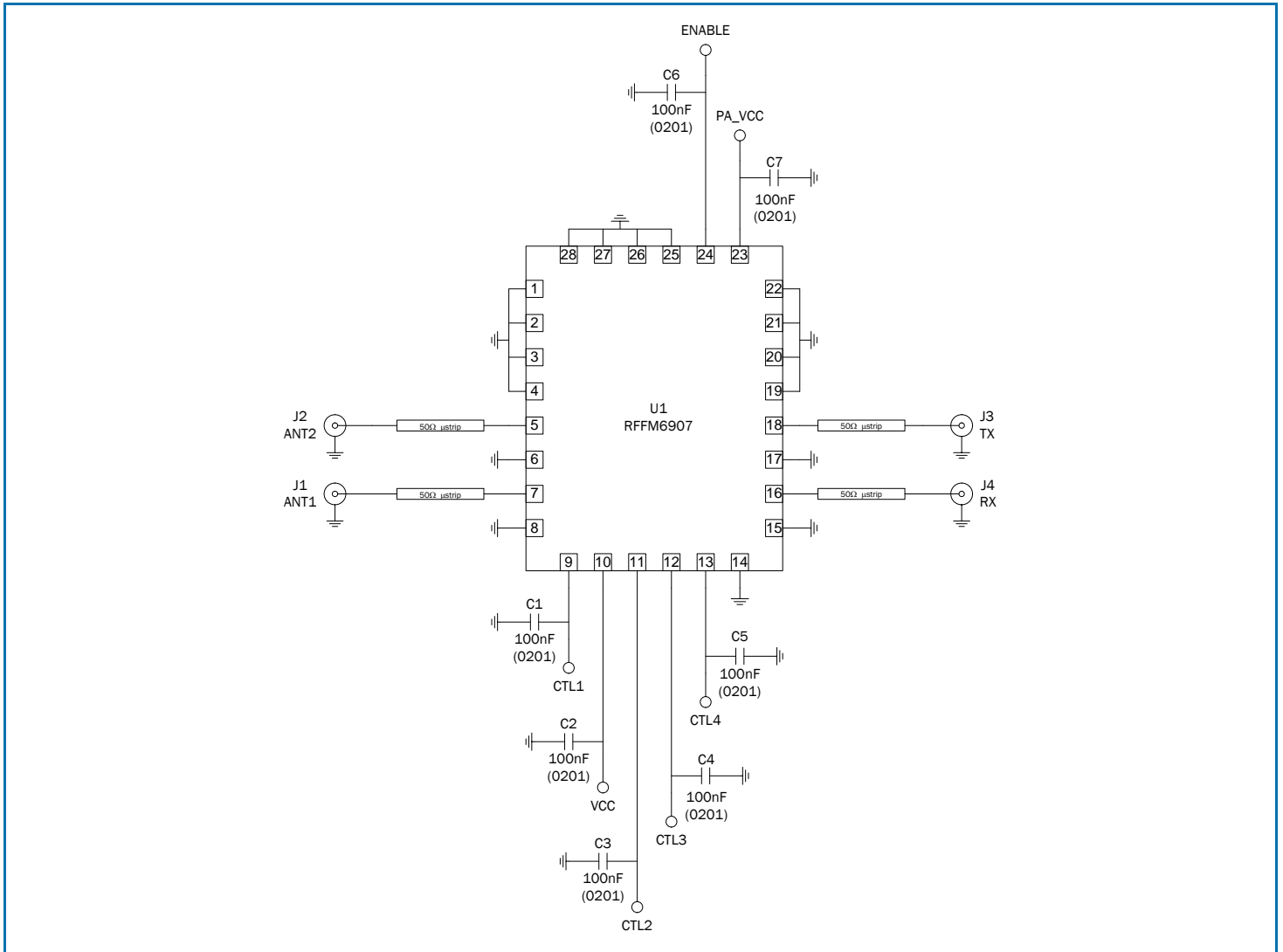

Pin Out

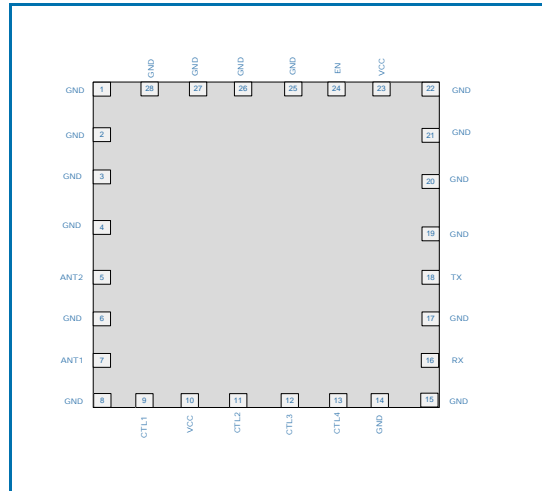

Package Outline and Branding Drawing (Dimensions in millimeters)

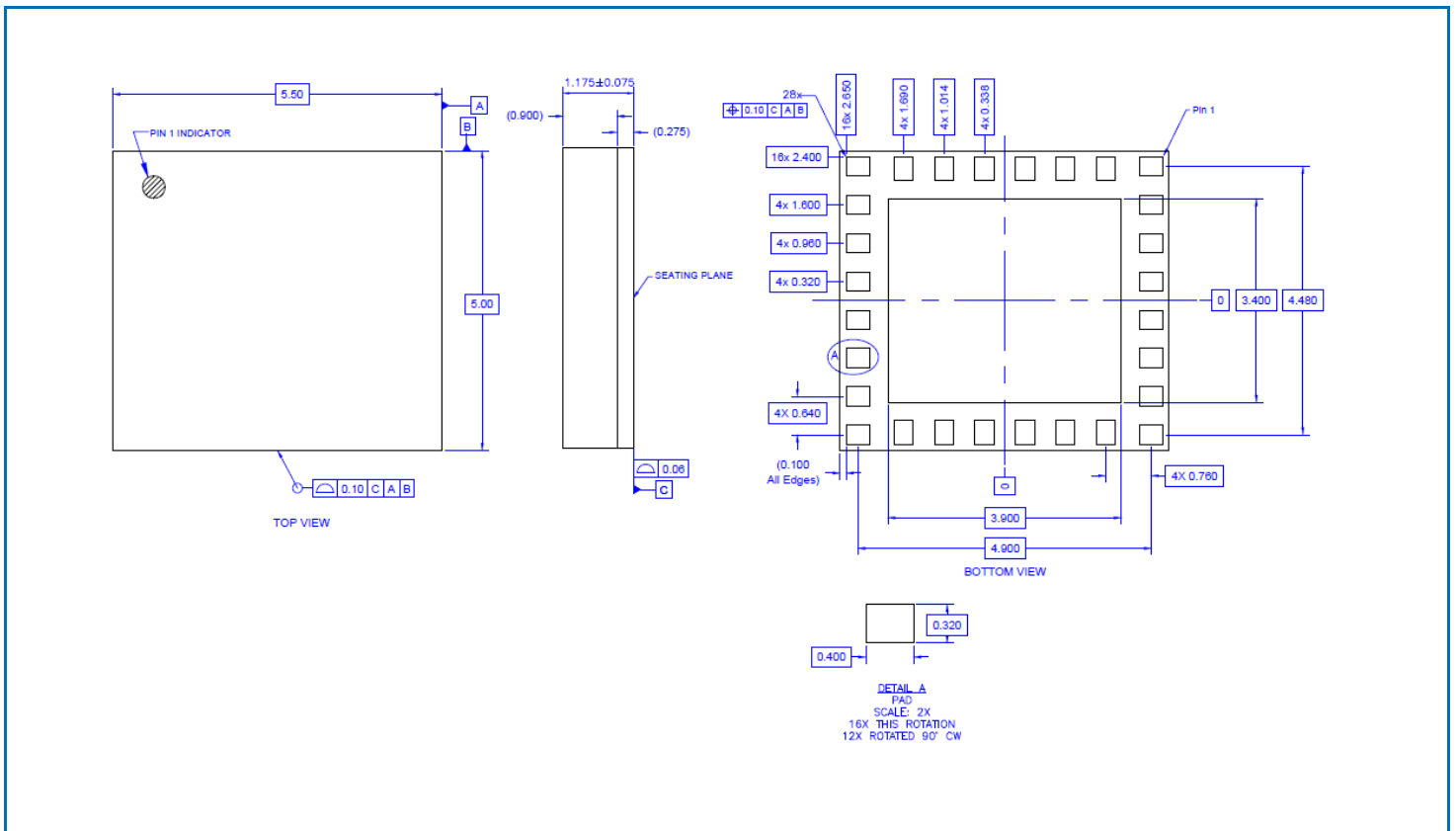

### PCB Design Requirements

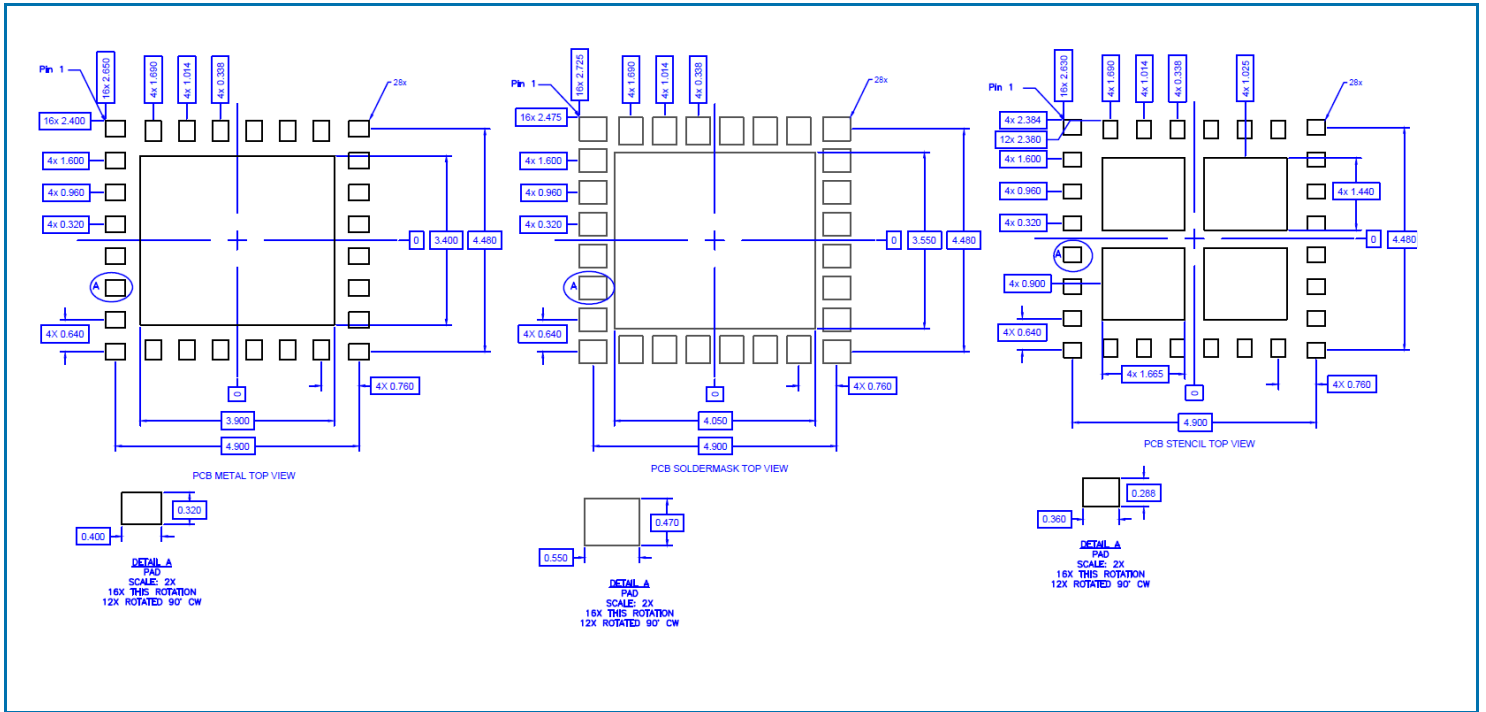

## Pin Names and Descriptions

Pin	Name	Description
1	GND	Ground
2	GND	Ground
3	GND	Ground
4	GND	Ground
5	ANT2	Antenna 2 Input/Output
6	GND	Ground
7	ANT1	Antenna 1 Input/Output
8	GND	Ground
9	CTRL1	Control Input
10	VCC	Diversity Switch Supply Voltage
11	CTRL2	Control Input
12	CTRL3	Control Input
13	CTRL4	Control Input
14	GND	Ground
15	GND	Ground
16	RX	Receive Port Output
17	GND	Ground
18	TX	Transmit Port Input
19	GND	Ground
20	GND	Ground
21	GND	Ground
22	GND	Ground
23	VCC	Power Amplifier Supply Voltage
24	ENABLE	Power Amplifier Enable
25	GND	Ground
26	GND	Ground
27	GND	Ground
28	GND	Ground
29	GND	Center Ground Flag